

AFRL-VA-WP-TR-1998-3009
This Report Supersedes WL-TR-93-3043



MISSILE DATCOM
USER'S MANUAL - 1997 FORTRAN 90 REVISION

William B. Blake
Air Force Research Laboratory
Air Vehicles Directorate
Wright-Patterson Air Force Base, Ohio 45433-7531

FEBRUARY 1998
FINAL REPORT FOR PERIOD APRIL 1993-DECEMBER 1997

APPROVED FOR PUBLIC RELEASE; DISTRIBUTION IS UNLIMITED

AIR VEHICLES DIRECTORATE
AIR FORCE RESEARCH LABORATORY
AIR FORCE MATERIEL COMMAND
WRIGHT PATTERSON AIR FORCE BASE, OHIO 45433-7562

NOTICE

WHEN GOVERNMENT DRAWINGS, SPECIFICATIONS, OR OTHER DATA ARE USED FOR ANY PURPOSE OTHER THAN IN CONNECTION WITH A DEFINITE GOVERNMENT-RELATED PROCUREMENT, THE UNITED STATES GOVERNMENT INCURS NO RESPONSIBILITY OR ANY OBLIGATION WHATSOEVER. THE FACT THAT THE GOVERNMENT MAY HAVE FORMULATED OR IN ANY WAY SUPPLIED THE SAID DRAWINGS, SPECIFICATIONS, OR OTHER DATA, IS NOT TO BE REGARDED BY IMPLICATION, OR OTHERWISE IN ANY MANNER CONSTRUED, AS LICENSING THE HOLDER, OR ANY OTHER PERSON OR CORPORATION; OR AS CONVEYING ANY RIGHTS OR PERMISSION TO MANUFACTURE, USE, OR SELL ANY PATENTED INVENTION THAT MAY IN ANY WAY BE RELATED THERETO.

THIS REPORT IS RELEASABLE TO THE NATIONAL TECHNICAL INFORMATION SERVICE (NTIS). AT NTIS, IT WILL BE AVAILABLE TO THE GENERAL PUBLIC, INCLUDING FOREIGN NATIONALS.

THIS TECHNICAL REPORT HAS BEEN REVIEWED AND IS APPROVED FOR PUBLICATION.

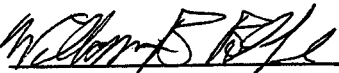

WILLIAM B. BLAKE
Project Engineer
Control Dynamics Branch

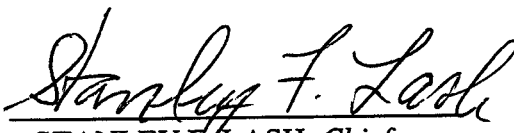

STANLEY E. LASH, *Chief*
Control Dynamics Branch
Flight Control Division

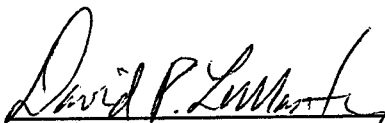

DAVID P. LEMASTER, *Chief*
Flight Control Division
Air Vehicles Directorate

REPORT DOCUMENTATION PAGE

*Form Approved
OMB No. 0704-0188*

Public reporting burden for this collection of information is estimated to average 1 hour per response, including the time for reviewing instructions, searching existing data sources, gathering and maintaining the data needed, and completing and reviewing the collection of information. Send comments regarding this burden estimate or any other aspect of this collection of information, including suggestions for reducing this burden, to Washington Headquarters Services, Directorate for Information Operations and Reports, 1215 Jefferson Davis Highway, Suite 1204, Arlington, VA 22202-4302, and to the Office of Management and Budget, Paperwork Reduction Project (0704-0188), Washington, DC 20503.

1. AGENCY USE ONLY (Leave blank)		2. REPORT DATE FEBRUARY 1998	3. REPORT TYPE AND DATES COVERED FINAL, 4/1/93-12/31/97	
4. TITLE AND SUBTITLE MISSILE DATCOM USER'S MANUAL - 1997 FORTRAN 90 REVISION			5. FUNDING NUMBERS PE: 62201F PR: 2403 TA: 05 WU: 95	
6. AUTHOR(S) WILLIAM B. BLAKE				
7. PERFORMING ORGANIZATION NAME(S) AND ADDRESS(ES) AIR VEHICLES DIRECTORATE AIR FORCE RESEARCH LABORATORY AIR FORCE MATERIEL COMMAND WRIGHT PATTERSON AFB OH 45433-7542			8. PERFORMING ORGANIZATION REPORT NUMBER	
9. SPONSORING/MONITORING AGENCY NAME(S) AND ADDRESS(ES) AIR VEHICLES DIRECTORATE AIR FORCE RESEARCH LABORATORY AIR FORCE MATERIEL COMMAND WRIGHT PATTERSON AFB OH 45433-7542 POC: WILLIAM B. BLAKE, AFRL/VACC (937) 255-6764			10. SPONSORING/MONITORING AGENCY REPORT NUMBER AFRL-VA-WP-TR-1998-3009	
11. SUPPLEMENTARY NOTES				
12a. DISTRIBUTION AVAILABILITY STATEMENT APPROVED FOR PUBLIC RELEASE, DISTRIBUTION IS UNLIMITED			12b. DISTRIBUTION CODE	
13. ABSTRACT (Maximum 200 words) THIS REPORT IS A USER'S MANUAL FOR THE 1997 FORTRAN 90 REVISION OF THE MISSILE DATCOM COMPUTER PROGRAM. THIS REPORT SUPERSEDES WL-TR-93-3043.				
14. SUBJECT TERMS MISSILE, AERODYNAMICS, STABILITY AND CONTROL			15. NUMBER OF PAGES 110	
			16. PRICE CODE	
17. SECURITY CLASSIFICATION OF REPORT UNCLASSIFIED	18. SECURITY CLASSIFICATION OF THIS PAGE UNCLASSIFIED	19. SECURITY CLASSIFICATION OF ABSTRACT UNCLASSIFIED	20. LIMITATION OF ABSTRACT SAR	

PREFACE

This report was prepared by the Air Vehicles Directorate, Air Force Research Laboratory, Wright Patterson AFB, Ohio. It documents the FORTRAN 90 version of Missile Datcom. The development of the original FORTRAN 77 version of Missile Datcom was performed by the McDonnell Douglas Corporation, St. Louis, Missouri. This report supersedes WL-TR-93-3043, which documents Missile Datcom Revision 6/93.

A list of the Missile Datcom Principal Investigators, USAF Project Engineers and individuals who made significant contributions to the development of this program is provided below.

PRINCIPAL INVESTIGATORS:

Steven R. Vukelich
Stan L. Stoy
Andrew A. Jenn
Marnix F.E. Dillenius
Keith A. Burns

USAF PROJECT ENGINEERS:

Jerry E. Jenkins
William B. Blake

CONTRIBUTORS:

Kurt D. Bausch
Carolyn S. Blake
Kevin D. Bruns
Joseph A. Castillo
Kenneth J. Deters
Bradley K. Drew
John F. Fay
Charles B. Heath
Joseph W. Herrmann
Edward Jenkins
Daniel J. Lesieutre
Marvin E. Moore
Bradley Osborne
Stanley C. Perkins
Richard D. Samuels
Frank M. Sawyer
James M. Simon
William D. Washington
John E. Williams

Questions about the program or suggestions for future improvements to the program should be directed to Mr. William Blake or Mr. James Simon, AFRL/VA, Wright-Patterson AFB, Ohio 45433, phone (937) 255-6764.

SUMMARY OF MISSILE DATCOM RELEASES

Contract	Investigator (Govt engineer)	Documentation	Release	Revision	Capability added
F33615-80-C-3605 (McDonnell Douglas)	S.R. Vukelich (J.E. Jenkins)	AFWAL TR-81-3130			Feasibility study only Recommended methods, code structure
F33615-81-C-3617 (McDonnell Douglas)	S.R. Vukelich (J.E. Jenkins)		1	12/84	Axisymmetric bodies Two fin sets with up to four fins each Automatic configuration trim
same	S.R. Vukelich (J.E. Jenkins)		2	11/85	Elliptical bodies Inlets at supersonic speeds Dynamic derivatives Four fin sets with up to eight fins each Experimental data substitution
same	S.L. Stoy (J.E. Jenkins)	AFWAL-TR-86-3091 (ADA 211086, 210128)	3	12/88	Expanded data substitution Configuration incrementing
none	(W.B. Blake)		4	7/89	Expanded body dynamic derivatives
F33615-86-C-3626 (McDonnell Douglas) F33615-87-C-3604 (NEAR Inc)	A.A. Jenn (J.E. Jenkins) M.F.E. Dillenius (W.B. Blake)	WL-TR-91-3039 (ADA 237817)	5	4/91	Inlets at subsonic/transonic speeds, additive drag Plume effects on body Six types of body protuberances Modified fin lateral center of pressure
F33657-89-D-2198 (McDonnell Douglas)	K.A. Burns (J.W. Herrmann)	WL-TR-93-3043 (ADA 267447)	6	6/93	UNIX workstation, PC compatibility Trailing edge flaps Folding fins Semi-submerged inlets
None	(W.B. Blake)		7	5/97	Fortran 90 compatibility. Expanded dynamic derivatives Revised body-fin upwash Modified base drag Modified fin longitudinal center of pressure

TABLE OF CONTENTS

	PAGE
1.0 INTRODUCTION	1
2.0 PROGRAM CAPABILITIES/INSTALLATION.....	2
2.1 TYPES OF DATA COMPUTED	2
2.1.1 Aerodynamics	2
2.1.2 Geometry	3
2.2 INSTALLATION ON COMPUTER SYSTEMS	3
2.2.1 Requirements	3
2.2.2 Input/Output	4
3.0 INPUT DEFINITION	5
3.1 NAMELIST INPUTS.....	6
3.1.1 Namelist FLTCON - Flight Conditions	8
3.1.2 Namelist REFQ - Reference Quantities	9
3.1.3 Namelist AXIBOD - Axisymmetric Body Geometry.....	9
3.1.4 Namelist ELLBOD - Elliptical Body Geometry.....	12
3.1.5 Namelist PROTUB - Protuberance Geometry	12
3.1.6 Namelist FINSETn - Define Fin Set n.....	13
3.1.7 Namelist DEFLCT - Panel Deflection Angles	15
3.1.8 Namelist TRIM - Trim Aerodynamics	15
3.1.9 Namelist INLET - Axisymmetric and 2-Dimensional Inlet Geometry.....	15
3.1.10 Namelist EXPR - Experimental Data Substitution.....	16
3.2 CONTROL CARD INPUTS	17
3.2.1 Control Card - General Remarks.....	18
3.2.2 Control Card Definition.....	18
3.3 TYPICAL CASE SET-UP.....	24
4.0 OUTPUT DESCRIPTION	57
4.1 NOMINAL OUTPUT	57
4.1.1 Input Error Checking.....	57
4.1.2 Listing of Case Input Data.....	58
4.1.3 Case Total Configuration Aerodynamic Output Summary	59
4.2 PARTIAL OUTPUT	60
4.2.1 Geometric Partial Output.....	60
4.2.2 Aerodynamic Partial Output	60
4.2.3 Dynamic Derivatives	62
4.3 EXTERNAL DATA FILES.....	85
4.3.1 Total Force and Moment PLOT Data	85
4.3.2 Pressure Distribution Data.....	85
4.4 ARRAY DUMPS	88
5.0 AERODYNAMIC METHODOLOGY	95
5.1 METHODS INCORPORATED	95
5.2 CHANGING A METHOD	95

LIST OF TABLES

	PAGE
Table 1 Namelist Alphanumeric Constants	25
Table 2 Equivalent Sand Roughness	26
Table 3 Flight Condition Inputs	27
Table 4 Reference Quantity Inputs	28
Table 5 Axisymmetric Body Geometry Inputs - Option 1	29
Table 6 Axisymmetric Body Geometry Inputs - Option 2	30
Table 7 Elliptical Body Geometry Inputs - Option 1	33
Table 8 Elliptical Body Geometry Inputs - Option 2	34
Table 9 Protuberance Inputs	36
Table 10 Fin Geometry Inputs	39
Table 11 Fin Geometry Inputs - HEX or ARC Airfoils	44
Table 12 Fin Geometry Inputs - User Airfoils	44
Table 13 Airfoil Designation Using the NACA Control Card	46
Table 14 Panel Deflection Inputs	47
Table 15 Trim Inputs	48
Table 16 Inlet Geometry Inputs	49
Table 17 Experimental Data Inputs	54
Table 18 Body Aerodynamic Work Array Names and Elements	89
Table 19 Fin Aerodynamic Work Array Names and Elements	90
Table 20 Inlet Incremental Data Array Names and Elements	91
Table 21 Static Coefficient and Derivative Data Array Names and Elements	91
Table 22 Dynamic Derivative Data Array Names and Elements	92
Table 23 Trimmed Aerodynamic Data Array Names and Elements	93
Table 24 Untrimmed Aerodynamic Data Array Names and Elements	93
Table 25 Flight Condition Data Array Names and Elements	94
Table 26 Configuration Attitude Data Array Names and Elements	94
Table 27 Body Alone Aerodynamic Methodology References	97
Table 28 Body Alone Aerodynamic Methodology Subroutines	98
Table 29 Fin Alone Aerodynamic Methodology References	99
Table 30 Fin Alone Aerodynamic Methodology Subroutines	100
Table 31 Inlet Aerodynamic Methodology References	101
Table 32 Inlet Aerodynamic Methodology Subroutines	101
Table 33 Fin-Body Synthesis Aerodynamic Methodology References	102
Table 34 Fin-Body Synthesis Aerodynamic Methodology Subroutines	102

LIST OF FIGURES

	PAGE
Figure 1 Body Geometry Inputs.....	31
Figure 2 Base-Jet Plume Interaction Parameters.....	32
Figure 3 Elliptical Body Geometry Nomenclature	35
Figure 4 Protuberance Shapes Available.....	37
Figure 5 Protuberance Example Input File	38
Figure 6 Fin Geometry Panel Break Points	40
Figure 7 Definition of Plain Trailing Edge Devices	41
Figure 8 Fin Numbering Orientation.....	42
Figure 9 Roll Attitude vs Fin Orientation.....	43
Figure 10 Fin Geometry Nomenclature - HEX and ARC Airfoils	45
Figure 11 Fin Geometry Nomenclature - User Airfoils	45
Figure 12 Top-Mounted 2-D Inlet/Diverter Geometry	50
Figure 13 Side-Mounted 2-D Inlet/Diverter Geometry.....	51
Figure 14 Axisymmetric Inlet/Diverter Geometry.....	52
Figure 15 Geometry Definition for Conformal and Semi-Submerged Inlets	53
Figure 16 Typical “Stacked” Case Set-Up	55
Figure 17 “Configuration Incrementing” Case Set-Up.....	56
Figure 18 Input Error Checking Output	64
Figure 19 Case Input Listing	65
Figure 20 Example of Default Substitutions for Incomplete Case Inputs.....	66
Figure 21 Total Configuration Aerodynamic Output Summary	67
Figure 22 Trimmed Output Summary	68
Figure 23 Body Geometry Output.....	69
Figure 24 Airfoil Geometry Output.....	70
Figure 25 Fin Geometry Output.....	71
Figure 26 Inlet Geometry Output.....	72
Figure 27 Base-Jet Plume Interaction Output.....	73
Figure 28 Protuberance Output	74
Figure 29 Body Alone Aerodynamic Partial Output	75
Figure 30 Fin Normal Force and Pitching Moment Partial Output.....	76
Figure 31 Fin Axial Force Partial Output	77
Figure 32 Airfoil Section Aerodynamic Partial Output.....	78
Figure 33 Inlet Aerodynamic Partial Output	79
Figure 34 Fin Set in Presence of the Body Partial Output.....	80
Figure 35 Fin Set in Presence of the Body Partial Output (continued).....	81
Figure 36 Carryover Interference Factors Partial Output.....	82
Figure 37 Panel Bending Moment Partial Output.....	83
Figure 38 Panel Hinge Moment Partial Output	83
Figure 39 Dynamic Derivative Output	84
Figure 40 Configuration Aerodynamics Plot File Output (“for003.dat”)	86
Figure 41 Trimmed Aerodynamics Plot File Output (“for003.dat”)	86
Figure 42 Body Pressure Distribution Plot File Output (“for010.dat”).....	86
Figure 43 Fin Pressure Distribution Plot File Output (“for011.dat”).....	87
Figure 44 Body Pressure and Local Mach Number Plot File Output (“for012.dat”).....	87

1.0 INTRODUCTION

In missile preliminary design it is necessary to quickly and economically estimate the aerodynamics of a wide variety of missile configuration designs. Since the ultimate shape and aerodynamic performance are so dependent upon the subsystems utilized, such as payload size, propulsion system selection and launch mechanism, the designer must be capable of predicting a wide variety of configurations accurately. The fundamental purpose of Missile Datcom is to provide an aerodynamic design tool which has the predictive accuracy suitable for preliminary design, and the capability for the user to easily substitute methods to fit specific applications.

2.0 PROGRAM CAPABILITIES/INSTALLATION

The computer code is capable of addressing a wide variety of conventional missile designs. For the purposes of this document, a conventional missile is one which is comprised of the following:

- An axisymmetric or elliptically-shaped body.
- One to four fin sets located along the body between the nose and base. Each fin set can be comprised of one to eight identical panels attached around the body at a common longitudinal position. Each fin may be deflected independently, as an all moving panel or as a fixed panel with a plain trailing edge flap.
- An airbreathing propulsion system.

To minimize the quantity of input data required, commonly used values for many inputs are assumed as defaults. However, all program defaults can be overridden by the user in order to more accurately model the configuration of interest.

2.1 TYPES OF DATA COMPUTED

2.1.1 Aerodynamics

The program computes the following aerodynamic parameters as a function of angle of attack for each configuration:

C_N	Normal Force Coefficient
C_L	Lift Coefficient
C_m	Pitching Moment Coefficient
X_{cp}	Center of Pressure in calibers from the moment reference center
C_A	Axial Force Coefficient
C_D	Drag Coefficient
C_Y	Side Force Coefficient
C_n	Yawing Moment Coefficient (body axis)
C_l	Rolling Moment Coefficient (body axis)
$C_{N\alpha}$	Normal force coefficient derivative with angle of attack
$C_{m\alpha}$	Pitching moment coefficient derivative with angle of attack
$C_{y\beta}$	Side force coefficient derivative with sideslip angle
$C_{n\beta}$	Yawing moment coefficient derivative with sideslip angle (body axis)
$C_{l\beta}$	Rolling moment coefficient derivative with sideslip angle (body axis)

For body alone or body plus fin combinations, the following parameters are also computed, all in the body axis system:

C_{mq}	Pitching moment coefficient derivative with pitch rate
----------	--

C_{Nq}	Normal force coefficient derivative with pitch rate
C_{Aq}	Axial force coefficient derivative with pitch rate
$C_{m\dot{\alpha}}$	Pitching moment derivative with rate of change of angle of attack
$C_{N\dot{\alpha}}$	Pitching moment derivative with rate of change of angle of attack
C_{lp}	Rolling moment coefficient derivative with roll rate
C_{np}	Yawing moment coefficient derivative with roll rate
C_{Yp}	Side force coefficient derivative with roll rate
C_{lr}	Rolling moment coefficient derivative with yaw rate
C_{nr}	Yawing moment coefficient derivative with yaw rate
C_{Yr}	Side force coefficient derivative with yaw rate

The derivative output can be in degrees or radians. Partial output results, which detail the components used in the calculations, are also optionally available.

It should be noted that the drag force (and drag coefficient) is different between the wind and stability axes systems if the missile body is at a sideslip angle (β) to the wind. However, wind axis drag and stability axis drag are the same at zero sideslip. In Missile Datcom, drag force is assumed to be in the stability axes system and axial force methods is assumed to be in the body axes system unless otherwise noted.

The program has the capability to perform a static trim of the configuration, using any fin set for control with fixed incidence on the other sets. The two types of aerodynamic output available from the trim option are as follows:

- Untrimmed data - Each of the aerodynamic force and moment coefficients are printed in a matrix, which is a function of angle of attack and panel deflection angle. This output is optional.
- Trimmed data - The trimmed aerodynamic coefficients, and trim deflection angle, are output as a function of angle of attack.

2.1.2 Geometry

All components of the configuration have their physical properties calculated and output for reference if requested. All data is supplied in the user selected system of units. The reference area and reference length are user defined.

2.2 INSTALLATION ON COMPUTER SYSTEMS

This section details the steps necessary to make the computer code functional on the user's computer system.

2.2.1 Requirements

In order for the Missile Datcom code to be successfully implemented on the user's computer system, there are three requirements which must be met, as follows:

- Language - The code is compatible with both FORTRAN 77 and FORTRAN 90.
- Namelist - The code has been designed with an internal FORTRAN NAMELIST emulator to allow the input and output (I/O) to be handled by namelist variables. This design is an exception to Standard FORTRAN but with the emulator as part of the code the program will run under Standard FORTRAN. The code is not easily converted to fixed field, rather than namelist input.
- I/O Scratch Files - The code uses the following logical file units: 2-12. All file units are accessed using formatted reads and writes. File units 2, 7 and 8 are used internally; file units 3, 4, 5, 6, 9, 10, 11 and 12 transfer data between the user and the code.

2.2.2 Input/Output

Eleven file units are used by the program. They are used as follows:

<u>Unit</u>	<u>Name</u>	<u>Usage</u>
2	for002.dat	Namelists for the input "case" are read from unit 8 and written to unit 2 by Subroutine READIN. The namelists for the "case" are read from unit 2.
3	for003.dat	Plot file of aerodynamic data, written at user request (using PLOT card) to unit 3 by Subroutines PLOT3, PLTTRM, or PLTUT9.
4	for004.dat	Common block data, written at user request (using WRITE card) to unit 4 by Subroutine SAVEF.
5	for005.dat	User input file, read from unit 5 by Subroutine CONERR.
6	for006.dat	Program output file, written to unit 6.
7	for007.dat	The FORMAT and WRITE control cards are written to unit 7 by Subroutine CONTRL and read by Subroutine SAVEF
8	for008.dat	User input cards read from unit 5 are written to unit 8 by Subroutine CONERR after they have been checked for errors
9	for009.dat	Body geometry data, written at user request (using PRINT GEOM BODY card) to unit 9 by Subroutines SOSE, VANDYK, or HYPERS.
10	for010.dat	Body pressure coefficient data at angle of attack, written at user request (using PRESSURES card) to unit 10 by Subroutines SOSE, VANDYK, or HYPERS.
11	for011.dat	Fin pressure coefficient data, written at user request (using PRESSURES card) to unit 11 by Subroutine FCAWPF.
12	for012.dat	Body pressure coefficient and local Mach number at zero angle of attack, written at user request (using PRESSURES) card to unit 12 from Subroutine SOSE.

The program is run in a "batch" mode. The user prepares an input file in accordance with the rules given in Section 3 of this report. This file must be renamed "for005.dat" prior to program execution. The program is then executed by typing the name of the executable file that is created upon compilation of the source code and linking of the object files. The program then executes and creates the output files requested by the case inputs. The primary output file, "for006.dat" is always written. A complete discussion of what is contained in this output file is given in Section 4 of this report. The optional plot, geometry, and pressure distribution output files are written only if requested.

3.0 INPUT DEFINITION

Inputs to the program are grouped by "case". A "case" consists of a set of input cards which define the flight conditions and geometry to be run. Provisions are made to allow multiple cases to be run. The successive cases can either incorporate the data of the previous case (using the input card SAVE) or be a completely new configuration design. The SAVE feature, for example, permits the user to define a body and wing (or canard) configuration in the first case and vary the tail design for subsequent cases.

The scheme used to input data to the computer program is a mixture of namelist and control cards. This combination permits the following:

- Inputs are column independent and can be input in any order.
- All numeric inputs are related to mnemonic (variable) names.
- Program input "flags" are greatly reduced. Required "flags" are identified by a unique alphabetic name which corresponds to the option selected.

The program includes an error checking routine which scans all inputs and identifies all errors. This process is a single-pass error checking routine; all errors are identified in a single "run". In addition, the program checks for necessary valid inputs, such as a non-zero Reynolds number. In some cases, the code will take corrective action. The type of corrective action taken is summarized later in this section.

Flexibility has been maintained for all user inputs and outputs. The following bullets summarize the program generality available:

- The units system can be feet, inches, meters, or centimeters. The default is feet.
- Derivatives can be expressed in degree or radian measure. Degree measure is the default.
- The body geometry can be defined either by shape type or by surface coordinates.
- The airfoil can be user defined, NACA, or supersonic shaped sections. The NACA sections are defined using the NACA designation. A hexagonally shaped supersonic section is the default.
- The configuration can be run at a fixed sideslip angle and varying body angle of attack, or a fixed aerodynamic roll angle and varying total angle of attack.
- The flight conditions can be user defined, or set using a Standard Atmosphere model. The capability to define wind tunnel test conditions as the flight conditions is also available. The default flight condition is zero altitude.

3.1 NAMELIST INPUTS

The required program inputs use FORTRAN namelists. Missile Datcom is similar to other codes which use the namelist input technique, but differs as follows:

- Namelist inputs are column independent, and can begin in any column including the first. If a namelist is continued to a second card, the continued card must leave column 1 blank. Also, the card before the continued card must end with a comma. The last usable column is number 79 if column 1 is used, and column 80 if column 1 is blank.
- The same namelist can be input multiple times for the same input case. The total number of namelists read, including repeat occurrences of the same namelist name, must not exceed 300.

The three namelist inputs

```
$REFQ SREF=1.,$  
$REFQ LREF=2.,$  
$REFQ ROUGH=0.001,$
```

are equivalent to

```
$REFQ SREF=1.,LREF=2.,ROUGH=0.001,$
```

- The last occurrence of a namelist variable in a case is the value used for the calculations.

The three namelist inputs

```
$REFQ SREF=1.,$  
$FLTCON NMACH=2.,MACH=1.0,2.0,$  
$REFQ SREF=2.,$
```

are equivalent to

```
$REFQ SREF=2.,$  
$FLTCON NMACH=2., MACH=1.0, 2.0,$
```

- Certain hollerith constants are permitted. They are summarized in Table 1. Note that any variable can be initialized by using the constant UNUSED; for example, LREF=UNUSED sets the reference length to its initialized value.
- Certain variables are input as arrays instead of single values, such as ALPHA. If the array list is too long to fit on one card, it must be continued on the following card with the variable name repeated and the array index of the first continued value. For example:

```
$FLTCON
```

NALPHA=20., ALPHA=0.,2.,4.,6.,8.,10.,12.,14.,16.,18.,20.,
 ALPHA(12)=22.,24.,28.,32.,36.,40.,44.,48.,52.,
 NMACH=5., MACH=0.2,0.8,1.5,2.0,3.0, ALT=0.,10000.,
 ALT(3)=20000.,30000.,40000.,\$

- The namelists can be input in any order.
- Only those namelists required to execute the case need be entered.

All Missile Datcom namelist inputs are either real numbers or logical constants. Integer constants will produce a nonfatal error message from the error checking routine and should be avoided. All namelist and variables names must be input in capital letters. This also applies to numerical values input in “E” format, i.e. REN=6.0E06 is acceptable, while REN=6.0e06 is not.

The namelist names have been selected to be mnemonically related to their physical meaning. The ten namelists available are as follows:

<u>Namelist</u>	<u>Inputs</u>
\$FLTCON	Flight Conditions (Angles of attack, Altitudes, etc.)
\$REFQ	Reference quantities (Reference area, length, etc.)
\$AXIBOD	Axisymmetric body definition
\$ELLBOD	Elliptical body definition
\$PROTUB	Protuberance information and geometry
\$FINSETn	Fin descriptions by fin set (n is the fin set number: 1, 2, 3 or 4)
\$DEFLCT	Panel incidence (deflection) values
\$TRIM	Trimming information
\$INLET	Inlet geometry
\$EXPR	Experimental data

Each component of the configuration requires a separate namelist input. Hence, an input case of a body-wing-tail configuration requires at least one of each of the following namelist inputs, since not all variables have default values assigned:

\$FLTCON	to define the flight conditions
\$AXIBOD or \$ELLBOD	to define the body
\$FINSET1	to define the most forward fin set
\$FINSET2	to define the first following fin set
\$FINSET3	to define the second following fin set
\$FINSET4	to define the third following fin set

The following namelists are optional since defaults exist for all inputs:

\$REFQ	to define the reference quantities
\$PROTUB	to define protuberance option inputs
\$DEFLCT	to define the panel incidence (deflection angles)
\$TRIM	to define a trim case
\$INLET	to define inlet geometry

\$EXPR to define experimental input data

Defaults for all namelists should be checked to verify the configuration being modeled does not include an unexpected characteristic introduced by a default.

The following sections describe each of the namelist inputs. Each section is accompanied by a figure which summarizes the input variables, their definitions, and units. Since the system of units can be optionally selected, the column "Units" specifies the generic system of units as follows:

L	Units of length; feet, inches, centimeters or meters
F	Units of force; pounds or Newtons
deg	Units of degrees; if angular, in angular degrees; if temperature, either degrees Rankine or degrees Kelvin
sec	Units of time in seconds

Exponents are added to modify the above. For example, L^2 means units of length squared, or area. Combinations of the above are also used to specify other units. For example, F/L^2 means force divided by area, which is a pressure.

Since it is difficult to discern the difference between the number zero "0" and the alphabetic letter "O", it should be noted that none of the namelist or namelist variable names contain the number zero in them. In general, the number zero and the letter "O" are not interchangeable unless so stated.

The program ascertains the configuration being modeled by the presence of each component namelist, even if no data is entered. The following rules for namelist input apply:

- Do not include a namelist unless it is required. Once read, the presence of a namelist (and, hence, a configuration component) can only be removed using the DELETE control card in a subsequent case. Simply setting all variables to their initialized values will not remove the configuration component.
- Do not include a variable within a namelist unless it is required. Program actions are often determined from the number and types of input provided.
- Do not over-specify the geometry. User inputs will take precedence over program calculations. Inputs that define a shape that is physically impossible will be used as specified. The program does not "fix-up" inconsistent or contradictory inputs.

3.1.1 Namelist FLTCON - Flight Conditions

This namelist defines the flight conditions to be run for the case. The program is limited to no more than 20 angles of attack and 20 Mach number/altitude combinations per case at a fixed sideslip angle, aerodynamic roll angle, and panel deflection angle. Therefore, a "case" is defined as a fixed geometry with variable Mach number/altitude and angles of attack.

The inputs are given in Table 3. There are two ways in which the aerodynamic pitch and yaw angles can be defined:

- Input ALPHA and BETA. If BETA is input and PHI is not, it is assumed that the body axis angles of attack (α) and sideslip angles (β) are defined.
- Input ALPHA and PHI. If PHI is input and non-zero, it is assumed that ALPHA is the total angle of attack (α) and PHI is the aerodynamic roll angle (ϕ).
- Input ALPHA, BETA, and PHI. The value for BETA is ignored if PHI is non-zero.

As a minimum the following variables must be defined:

NALPHA	number of angles of attack to run (must be at least 2)
ALPHA	angle of attack schedule (matching NALPHA)
NMACH	number of Mach numbers or speeds
MACH or VINF	Mach number or speed schedule (matching NMACH)

The ALT, REN, TINF and PINF data must correspond to the MACH or VINF inputs. The ALPHA and MACH dependent data can be input in any order; the code will sort the data into ascending order.

Reynolds number is always required. Three types of inputs are permitted to satisfy the Reynolds number requirement:

- Specify Reynolds number per unit length using REN
- Specify the altitude using ALT, and the speed using MACH or VINF (Reynolds number is computed using the 1962 Standard Atmosphere model)
- Specify pressure and temperature using PINF and TINF, and the speed using MACH or VINF (typical of data available from a wind tunnel test)

User supplied data will take precedence over program calculations. Hence, the user can override any default or Standard Atmosphere calculation. The default condition is sea-level altitude (ALT=0.) if the wrong combination of inputs are provided and the Reynolds number cannot be calculated.

3.1.2 Namelist REFQ - Reference Quantities

Inputs for this namelist are optional and are defined in Table 4. A vehicle scale factor (SCALE) permits the user to input a geometry that is scaled to the size desired. This scale factor is used as a multiplier to the user defined geometry inputs; it is not applied to the user input reference quantities (SREF, LREF, LATREF). If no reference quantities are input, they are computed based upon the scaled geometry. XCG is input relative to the origin of the global coordinate system (X=0, Figure 1) and is scaled using SCALE.

In lieu of specifying the surface roughness height ROUGH, the surface Roughness Height Rating (RHR) can be specified. The RHR represents the arithmetic average roughness height variation in millionths of an inch. Typical values of ROUGH and RHR are given in Table 2.

3.1.3 Namelist AXIBOD - Axisymmetric Body Geometry

An axisymmetric body is defined using this namelist. The namelist input variables are given in Tables 5 and 6 and a sketch of the geometric inputs are given in Figure 1. The body can be specified in one of two ways:

OPTION 1: The geometry is divided into nose, centerbody, and aft body sections. The shape, overall length, and base diameter for each section are specified. Note that not all three body sections need to exist on a configuration; for example, a nose-cylinder configuration does not require definition of an aft body.

OPTION 2: The longitudinal stations and corresponding body radii are defined, from nose to tail.

The program uses the input value for NX to determine which option is being used. If NX is not input then Option 1 inputs are assumed, if it is input, Option 2 inputs are assumed. In multiple case runs, NX can be reset to its initialized value (to simulate the variable as not input) by specifying "NX=UNUSED".

Many simple body shapes (such as a cone-cylinder) can be defined using either Option 1 or Option 2 inputs. For these shapes, the same result will be obtained at all Mach numbers greater than 1.2. Below this speed, different results will be obtained due to differences in the aerodynamic methodology. See section 5 for further details.

If Option 2 is selected, the program generates a body contour based on the user specified values of X, R, and DISCON. Above a Mach number of 1.2, many additional points in between the user specified input coordinates will be generated. The resulting contour can contain more than 1000 points. If the PRINT GEOM BODY control card is used, this contour will be written to tape unit 9 ("for009.dat").

It is highly recommended that Option 1 be used when possible. The program automatically calculates the body contour based upon the segment shapes using geometry generators. Hence, more accurate calculations are possible. Even when Option 2 is used, some Option 1 inputs may be included. This identifies where the code should insert break points in the contour. If these parameters are not input, they are selected as follows:

LNOSE	Length of the body segment to where the radius first reaches a maximum
DNOSE	The diameter at the first radius maximum
LCENTR	Length of the body segment where the radius is constant
DCENTR	Diameter of the constant radius segment
LAFT	The remaining body length
DAFT	Diameter at the base
DEXIT	Not defined (implies that base drag is not to be included in the axial force calculations, see next page)

If body coordinates are input using the variables NX, X, R, and DISCON, the nose is spherically blunted, and results using the Second Order Shock Expansion method are desired (only if $M > 1.2$), the geometry must be additionally defined using the following:

- BNOSE must be specified

- TRUNC must be set to .FALSE.
- The first five (5) points in the X and R arrays must lie on the spherical nose cap [i.e., X(1), X(2), X(3), X(4), X(5), R(1), R(2), R(3), R(4), and R(5) are spherical cap coordinates].

The following summarizes the input generality available:

- X(1) does not have to be 0.0; an arbitrary origin can be selected.
- Five shapes can be specified by name:

CONICAL (CONE) - cone or cone frustum (default for boattails and flares)

OGIVE - tangent ogive (default for noses)

POWER - power law*

HAACK - L-V Haack (length-volume constrained)*

KARMAN - von Karman (L-D Haack; length-diameter constrained)*

- If DAFT<DCENTR the afterbody is a boattail.**
- If DAFT>DCENTR the afterbody is a flare.**
- If LAFT is not input, aft body (boattail or flare) does not exist.

* applies to noses only

** DAFT must not be equal to DCENTR

If DEXIT is not input, or set to UNUSED, the base drag computed for the body geometry will not be included in the final computed axial force calculations. To include a "full" base drag increment, a zero exit diameter must be specified (DEXIT=0.).

The inputs for base-jet plume interaction effects are defined using Option 1. Incremental forces and moments due to jet induced boattail separation and separation locations on aft fins are calculated if these inputs are used.

- This option should only be run for supersonic cases (i.e. $M > 1.2$)
- The calculations will be done for three types of aft bodies: conical boattail, ogival boattail, or cylindrical (i.e. no boattail). Error messages will be printed to the output file and the calculations skipped if any other aft body is defined.
- If BASE=.FALSE. or is not input the calculations will be skipped.
- DEXIT must not equal zero if this option is used.
- The jet Mach number (JMACH), jet to freestream static pressure ratio (PRAT), and jet to freestream stagnation temperature ratio (TRAT) must be specified for each freestream Mach number or velocity input in the namelist FLTCON. For subsonic or transonic freestream Mach numbers or velocities, dummy values must be input for

JMACH, PRAT, and TRAT. The user must be careful to match these inputs with the proper freestream conditions.

- If a portion of the fins are located on the boattail or base, the boattail separation locations will be calculated and output at each fin roll angle. However, if the fins do not extend to the boattail, the separation locations will be skipped.

3.1.4 Namelist ELLBOD - Elliptical Body Geometry

Elliptically-shaped cross section bodies are defined using this namelist. The inputs are similar to those for the axisymmetric body geometry (AXIBOD), and are shown in Tables 7 and 8. The types of shapes available, and the limitations, are the same as those given for axisymmetric bodies. However, the base-jet plume interaction input options in namelist AXIBOD are not available in namelist ELLBOD. Please read Section 3.1.3 for limitations.

Note that the body cross section ellipticity can vary along the body longitudinal axis. Sections which are taller-than-wide and wider-than-tall can be mixed to produce "shaped" designs. The shape of the sections is controlled by the variables ENOSE, ECENTR, and EAFT or ELLIP, H, and W. Note that the full nose width (WNOSE) is used for Option 1 while the nose half width (W) is used for Option 2

3.1.5 Namelist PROTUB - Protuberance Geometry

Missile protuberances can be input using this namelist. Only axial force coefficient is calculated for protuberances, and this contribution is added to the body axial force coefficient. Table 9 shows the inputs required. Figure 4 shows the different protuberance shapes available. The following defines the inputs required for protuberance calculations:

- NPROT is the number of protuberance sets. A protuberance set is made up of protuberances at the same axial location with the same size and shape. Therefore, it is only necessary to describe the geometry of one individual protuberance per set. The maximum number of protuberance sets is 20.
- NLOC is the number of protuberances in each protuberance set. NLOC accounts for the number of identical protuberances located around the missile body at a given axial location.
- The axial location of a protuberance (XPROT) should be input at the protuberance geometric centroid. An approximation of the centroid will be adequate for the analysis. The location is used to calculate the average boundary layer thickness over the protuberance length.
- VCYL, HCYL, BLOCK, and FAIRING type protuberances have 1 member. LUG types have 4 members and SHOE types have 3 members. (Refer to Figure 4)
- All inputs for LPROT, WPROT, HPROT, and OPROT are in sequential order based upon the members specified with the protuberance type (PTYPE) input.
- The FAIRING type protuberance should always have a zero offset. The code will assume a zero offset even if a non-zero offset is input.

More complex protuberance shapes can be analyzed by a component build-up method. Each member is treated as a separate protuberance. Combinations of vertical cylinders, horizontal cylinders, and flat plates or blocks can be input at specified offsets from the missile body. If a FAIRING type protuberance is used in a component build-up, the offset should be zero.

Figure 5 shows an example input file for a missile with several protuberances.

3.1.6 Namelist FINSETn - Define Fin Set n

Table 10 describes the variables needed to be input for fin set planform geometry descriptions. Optional fin cross-section inputs are described in Table 11. Special user specified fin cross-sections can be input using the variables in Table 12. The user may specify up to four non-overlapping fin sets. The variable "n" in the namelist specifies the fin set number. Fin sets must be numbered sequentially from the front to the back of the missile beginning with fin set one. An input error will occur if "n" is zero or omitted. The code allows for between 1 and 8 geometrically identical panels to be input per fin set. The panels may be arbitrarily rolled about the body and can be given dihedral.

The user selects "break points" on the panel (Figure 6). A "break point" specifies a change in leading or trailing edge sweep angle. Also a break point may specify a change in airfoil section, but the section must be of the same type (i.e., a change in section type cannot go from a NACA to an ARC) only the proportions can change. The location of each "break point" is defined by specifying its semi-span station (SSPAN) from the vehicle centerline and distance from the first body station to the chord leading edge (XLE). The "break point" chord leading edge array (XLE) can be defined by simply specifying the root chord leading edge [XLE(1)] and the sweep angles of each successive panel segment if the semi-span stations are input. Note that only those variables that uniquely define the fin need to be entered. Redundant inputs can lead to numerical inconsistencies and subsequent computational errors.

It is the user's responsibility to assure that the fins are (1) on the body surface, and (2) do not lie internal to the body mold line. The program does not check for these peculiarities. If SSPAN(1)=0 is input, the program will assume that the panel semi-span data relative to its root chord are supplied. The code will automatically interpolate the body geometry to place the panel on the body surface with the root chord parallel to the body centerline.

If the fin panels are positioned on a varying radii segment, select the root chord span station [SSPAN(1)] such that the center of the exposed root chord is on the surface mold line. This constraint is illustrated in Figure 6. Physically this places part of the panel within the body and part offset from the body. If SSPAN(1)=0, the code will interpolate the body geometry at the root chord center and add the body radius at this point to the user defined values in the SSPAN array.

The panel sweep angle (SWEEP) can be specified at any span station for each segment of the panels. If STA=0., the sweep angle input is measured at the segment leading edge; if STA=1., the sweep angle input is measured at the segment trailing edge. Note that some aerodynamic methods are very sensitive to panel sweep angle. For small span fins, small errors in the planform inputs can create large sweep angle calculation errors. It is recommended that exact sweep angles be specified wherever possible; for example, if the panel trailing edge is unswept, specifying SWEEP=0. and STA=1. will minimize calculation error. Then the leading edge sweep will be computed by the code internally using the SSPAN and CHORD inputs.

Plain trailing edge devices may be modelled in Missile Datcom. This is accomplished via the CFOC array which is the flap chord to fin chord ratio, c_f/c . Trailing edge devices can be either full span or partial span subject to certain limits specified below. The trailing edge devices can not have a taper ratio greater than 1.0, and the hinge line must be straight regardless of the number of segments comprising the trailing edge device. A partial span trailing edge device is specified by setting CFOC=0 for those chord/span stations that are not part of the trailing edge device. Examples of acceptable and unacceptable geometries are shown in Figure 7 as well as the corresponding input values for the variable arrays CFOC, CHORD and SSPAN. A special case where the trailing edge device extends to the tip of a fin with a taper ratio of zero is also shown in Figure 7. While any value of CFOC will result in the correct flap chord at the tip (since the tip chord is zero), the user must specify a CFOC=1.0 since a value of CFOC=0 would indicate the trailing edge device does not exist at this chord/span station. The user should also be aware of the following:

- Hinge moments for trailing edge devices are not calculated.
- The increase in profile drag due to trailing edge deflection is not calculated.
- Trailing edge deflection angles are measured with respect to the freestream and not relative to the hinge line. This is an important distinction for highly swept hinge lines.
- The variable SKEW does not apply to trailing edge devices. This means that the user must manually reduce the tangent of the deflection by the cosine of the SKEW angle.

Since all panels are assumed to be planar (i.e., no tip dihedral), all inputs must be "true view". Once the planform of a single panel is defined, all fins of the set are assumed to be identical. The number of panels present is defined using the variable NPANEL. Each panel may be rolled to an arbitrary position around the body using the variable PHIF. PHIF is measured clockwise from top vertical center (looking forward from behind the missile) as shown in Figure 8. Each panel may also contain a constant dihedral. A panel has zero dihedral when it is aligned along a radial ray from the centerline (see Figure 8). The variable used to specify dihedral is GAM. GAM is positive if the panel tip chord is rotated clockwise.

Different aerodynamics will be computed depending upon whether the FLTCON namelist variable PHI, or the FINSETn namelist variable PHIF, is used to roll the geometry. Figure 9 depicts the usage of the roll options. The variable "PHI" means that the body axes system is to be rolled with the missile body, whereas PHIF keeps the aerodynamics in a non-rolled body axis, but rather locates the fin positions around the body. PHIF must be input for each panel, while PHI rolls the whole configuration.

When defining more than one fin set, the sets must always be input in order as they are mounted on the body from nose to tail. This means that FINSET2 must always be aft of FINSET1, FINSET3 must always be aft of FINSET2 and FINSET4 must always be aft of FINSET3. In addition, fin sets must never have their planforms overlap one another. There must be sufficient space between the forward fin trailing edge and aft fin leading edge to avoid violating the assumptions made by the aerodynamic computations. It is assumed by the aerodynamic model that the vortices are fully rolled up when they pass the control points of the next downstream set of fins. In reality the vortex sheet does not fully roll up until it is at least four semispans downstream. If two fin sets are closer than this, the results may be in error since the use of a vortex filament model may introduce too much vorticity. The closer the spacing the larger the error may be. No error message is written if adjacent fin sets are defined too close to one another.

Panels with cut-out portions can be modeled by using one of the ten available fin segments as a transition segment. This is accomplished by giving the segment a small span, such as 0.0001, and specifying the segment root and tip chords to transition into the cut-out portion of the fin.

Four types of airfoil sections are permitted - hexagonal (HEX), circular arc (ARC), NACA airfoils (NACA), and user defined (USER). HEX, ARC, and USER type sections require additional input variables in Namelist FINSETn (see Tables 11 and 12). An NACA section must be defined using a separate NACA control card. The NACA designation rules for the sections allowed and example control card inputs are shown in Table 13. See Section 3.2 for further discussion of the NACA option.

Only one type of airfoil section can be specified per fin set, and this type is used for all chordwise cross sections from root to tip. Diamond-shaped sections are considered a special case of the HEX type; hence, hexagonal and diamond sections can coexist on the same panel. The airfoil proportions can be varied from span station to span station. Camber effects on normal force and pitching moment are only computed for NACA and USER type sections at $M=0.8$ and below. Camber defined using HEX or ARC inputs only affects drag calculations.

3.1.7 Namelist DEFLCT - Panel Deflection Angles

This namelist permits the user to fix the incidence angle for each panel in each fin set. The variables are given in Table 14. Note that the panel numbering scheme is assumed to be that shown in Figure 8. The array element of each deflection array corresponds to the panel number.

The scheme for specifying deflection angles is unique, yet concise. The scheme used is based upon the body axis rolling moment:

"In Missile Datcom a positive panel deflection is one which will produce a negative (counterclockwise when viewed from the rear) roll moment increment at zero angle of attack and sideslip."

3.1.8 Namelist TRIM - Trim Aerodynamics

This namelist instructs the program to statically trim the vehicle longitudinally ($C_m=0$). The inputs are given in Table 15. Note that only one fin set can be used for trimming. The user specifies the range of deflection angles desired using DELMIN and DELMAX and the code will try to trim the vehicle for each angle of attack specified using the allowable fin deflections. This option will not trim the vehicle at a specific angle of attack if the deflection required is outside the range set by the values of DELMIN and DELMAX.

The sign convention described in Section 3.1.7 would result in deflections of opposite sign for a trim in pitch. To prevent this, the program automatically reverses the sign of any panel which is deflected on the left hand side of the configuration ($180^\circ < \text{PHIF} < 360^\circ$). This results in a "positive deflection is trailing edge down" convention for the trim results. The sense of the deflection for any panel can be reversed using the ASYM logical variable. This allows the user to recover the sign convention described in Section 3.1.7 for the trim results. Note that this procedure will usually result in a non-zero rolling moment at the trim condition in pitch. If the ASYM flag is set for all panels, the sign convention for the trim results becomes "positive deflection is trailing edge up".

3.1.9 Namelist INLET - Axisymmetric and 2-Dimensional Inlet Geometry

This namelist is used to model the inlet and diverter geometry. Axisymmetric, two-dimensional side mounted, and two-dimensional top mounted inlets can be described. The inlets may be covered or uncovered and oriented in any position about the missile body. Inlet normal force, pitching moment, side force, yawing moment, and axial force are calculated. The methods are valid for subsonic, transonic, and supersonic speeds. Table 16 shows the INLET namelist inputs, and Figures 12-14 show the inlet/diverter geometry for each type of inlet. The inlets may have a boundary layer diverter, be conformal (diverter height HDIV=0), or be semi-submerged (diverter height HDIV<0). The methods used for the inlets are the same regardless of whether the inlet has a diverter or is semi-submerged, and they are not applicable to chin inlets. The variable HDIV is used to determine whether a diverter exist. Figure 15 shows examples of two-dimensional and axisymmetric inlets that are conformal or semi-submerged.

- Inlet roll orientation uses the same convention as the fin panel roll orientation.
- Inlet height and width or inlet diameter is input at five axial locations described in Figures 12-14:
 - 1) leading edge or tip
 - 2) cowl lip leading edge
 - 3) midbody start
 - 4) boattail start
 - 5) boattail end
- If the inlet is covered (COVER=.TRUE.), no flow is allowed into the inlet. The inlet is plugged between stations 1 and 2, flush with the inlet face.

Inlet additive drag or spillage drag can be calculated for external compression inlets operating at off-design conditions ($M < M_{\text{design}}$) for Mach numbers greater than 1. Whenever flow spillage occurs, the mass flow ratio is less than one, and additive forces are generated on the deflected streamtube captured by the inlet. If the inlet operates on-design, the ramp shock lies on the inlet face and on the cowl lip. In these cases, the maximum mass flow ratio is one (zero spillage) and the minimum additive forces are zero.

- If the inlet is covered (COVER=.TRUE.), the additive drag calculations will be skipped.
- If ADD=.FALSE., or is not input the additive drag calculations will be skipped.
- Mass flow ratio (MFR) must be specified for each freestream Mach number or velocity given in namelist FLTCON. For Mach numbers less than 1, dummy values must be input for MFR. The user must be careful to match these inputs with the proper freestream conditions.
- The additive drag is calculated at zero angle of attack and assumed to remain constant for all angles of attack.

3.1.10 Namelist EXPR - Experimental Data Substitution

This namelist is used to substitute experimental data for the theoretical data generated by the program. The variables to be input are shown in Table 17. Use of namelist EXPR does not stop the

program from calculating theoretical data, but rather the experimental data is used in configuration synthesis, and it is the experimental data that is used for the component aerodynamics for which it is input.

Experimental data may be substituted for any configuration component or partial configuration. Experimental data is input at a specific Mach number. When using namelist EXPR, the case must be run at the Mach number for which you are substituting experimental data. However, the experimental data being input may have different reference quantities and a different center of gravity location than the case being run.

Experimental data input for a fin alone is input as panel data, not as total fin set data. The user should note that experimental data for fin alone $C_{m\alpha}$ is not used in the configuration synthesis process. Instead fin alone $C_{N\alpha}$ (the experimental value if input) is used to determine the fin contribution to $C_{m\alpha}$ during configuration synthesis. If body alone experimental data and body-fin experimental data are input for the same case, the body data is ignored in configuration synthesis. If experimental $C_{m\alpha}$ data is input for a body + 1 fin set for a multi-fin set configuration, the calculated contributions to $C_{m\alpha}$ of the other fin sets are added to the experimental data.

Since the experimental namelist forms the basis for configuration incrementing, the lateral directional coefficients are included to allow for sideslip cases. These coefficients are input the same as the longitudinal coefficients. However, if the lateral directional coefficients are input, the lateral directional beta derivatives will not be computed or output.

The following rules apply to the use of namelist EXPR.

- It is assumed that the coefficients in EXPR are for the same sideslip and/or aerodynamic roll as the case being run.
- Separate namelist EXPR must be specified for each Mach number.
- Each namelist EXPR must end with a \$END card.
- Separate namelist EXPR must be specified for each partial configuration for which experimental data is to be input, (i.e., body, body + 1 fin set, etc)
- Separate namelist EXPR must be specified for each reference quantity change.

Example:

The user has experimental data available for a body + 2 fin set configurations and is interested in the effects of adding a booster containing a third fin set. The would then use namelist EXPR to input the experimental data. When the configuration is synthesized, it would use the experimental data for body + 2 fin sets and theoretical data for fin set three.

3.2 CONTROL CARD INPUTS

Control cards are one line commands which select program options. Although they are not required inputs, they permit user control over program execution and the types of output desired. Control cards enable the following:

- Printing internal data array results for diagnostic purposes (DUMP)
- Outputting intermediate calculations (PART, BUILD, PRESSURES, PRINT AERO, PRINT EXTRAP, PRINT GEOM, PLOT, NAMELIST, WRITE, FORMAT)
- Selecting the system of units to be used (DIM, DERIV)
- Defining multiple cases, permitting the reuse of previously input namelist data or deleting namelists of a prior case (SAVE, DELETE, NEXT CASE)
- Adding case titles or comments to the input file and output pages (*, CASEID)
- Limits the calculations to longitudinal aerodynamics (NO LAT)

3.2.1 Control Card - General Remarks

Many different control cards are available. There is no limit to the number of control cards that can be present in a case. If two or more control cards contradict each other, the last control card input will take precedence. All control cards must be input as shown, including any blanks. Control cards can start in any column but they cannot be continued to a second card. Misspelled cards are ignored. Control cards can be located anywhere within a case.

Once input, the following control cards remain in effect for all subsequent cases:

DIM FT	DIM IN	DIM CM	DIM M
FORMAT	HYPER	INCRMT	NOGO
NO LAT	PLOT	SOSE	WRITE

The following control cards are effective only for the case in which they appear:

BUILD	CASEID	DAMP	DELETE name
DUMP CASE	DUMP name	NAMELIST	PART
PRESSURES	PRINT AERO name	PRINT GEOM name	
SAVE	SPIN	TRIM	

These control cards can be changed from case to case:

DERIV DEG	DERIV RAD	NACA
-----------	-----------	------

The only control card that can be optionally saved, from case-to-case, is the NACA card.

3.2.2 Control Card Definition

Available control cards are summarized as follows:

BUILD

This control card instructs the program to print the results of a configuration build-up. All configurations which can be built from the components defined will be synthesized and output, including isolated data (e.g., body alone, fin alone, etc.). Component build-up data is not provided if the TRIM option is selected. This control card is effective only for the case in which it appears.

CASEID

A user supplied title to be printed on each output page is specified. Up to 73 characters can be specified (card columns 8 to 80). This control card is effective only for the case in which it appears.

DAMP

When DAMP control card is input dynamic derivatives are computed and the results output for the configuration. The longitudinal (pitch rate) derivatives are non-dimensionalized by the quantity $q \cdot LREF / (2 \cdot VINF)$. The lateral-directional (roll rate, yaw rate) derivatives are non-dimensionalized by the quantities $p \cdot LATREF / (2 \cdot VINF)$ and $r \cdot LATREF / (2 \cdot VINF)$ respectively. Dynamic derivatives for configuration components or partial configurations may be output using the PART or BUILD control cards respectively. This control card is effective only for the case in which it appears.

DELETE name1,name2

This control card instructs the program to ignore a previous case namelist input that was retained using the SAVE control card. All previously saved namelists with the names specified will be purged from the input file. Any new inputs of the same namelist will be retained. At least one name (name1) must be specified. The DELETE control cards are effective only for the case in which they appear.

DIM IN, DIM FT, DIM CM, or DIM M

This control card sets the system of units for the user inputs and program outputs. The four options are inches (DIM IN), feet (DIM FT), centimeters (DIM CM), and meters (DIM M). The default system of units is feet. Once the system of units has been set, it remains set for all subsequent cases of the "run".

DERIV DEG or DERIV RAD

All output derivatives are set to either degree (DERIV DEG) or radian (DERIV RAD) measure. The default setting is degree. The derivative units can be changed more than once during the run by inputting multiple DERIV cards.

DUMP CASE

Internal data blocks, used in the computation of the case, are written on tape unit 6 ("for006.dat"). This control card automatically selects partial output (PART). This control card is effective only for the case in which it appears.

DUMP name1,name2

This permits the user to write selected internal data blocks or common blocks on tape unit 6 ("for006.dat"). At least one name (name1) must be specified. The arrays will be dumped in units of feet,

pounds, degrees or degrees Rankine. Tables 18-26 show the common block dump names and provide a definition of each common block variable. The DUMP control cards are effective only for the case in which they appear.

FORMAT (format)

This control card is used in conjunction with the WRITE control card. It specifies the format of the data to be printed to tape unit 4 (“for004.dat”). The format is input starting with a left parenthesis, the format and a right parenthesis. This is exactly the same as a FORTRAN FORMAT statement. Because of the code structure, alphanumeric data must not be printed. For example:

FORMAT ((8(2X,F10.4))	is legal
FORMAT ('X=',F10.4)	is illegal

The default format is 8F10.4, and will be used if the FORMAT control card is not present. Multiple formats can be used. The last FORMAT read will be used for all successive WRITE statements until another FORMAT is encountered. Hence, the FORMAT must precede the applicable WRITE.

HYPER

This control card causes the program to select the Newtonian flow method for bodies at any Mach number above 1.4. HYPER should normally be selected at Mach numbers greater than 6.

INCRMT

This card is used to set the configuration incrementing flag. Configuration incrementing uses the first case of a run to determine correction factors for the longitudinal and lateral aerodynamic coefficients. These correction factors are computed by comparing theoretical and experimental values for each coefficient for which data is input. The experimental values are input using namelist EXPR. During subsequent cases of the run, the correction factors are applied to coefficients for which experimental data was input in the first case. This provides the user with a method to evaluate changes in a configuration.

The INCRMT card must be input in the first case of a run. The first case must be run at the same Mach number as the experimental data which is input. Once the increment flag is set it cannot be deleted during that run.

The following restrictions apply:

- All cases of a run must have the same number of fin sets.
- All cases of a run must have the same sideslip or aerodynamic roll angle as the first case (BETA or PHI as specified in namelist FLTCON).
- The first case must be run at exactly the same angles of attack as the experimental data being input.
- All cases must be run within the same Mach regime (subsonic, transonic, or supersonic) as the experimental data.

- Experimental data can only be input in the first case and only for the complete configuration. No additional data can be substituted.
- To increment $C_{Y\beta}$ and $C_{N\alpha}$ experimental data must be input for C_Y and C_N .

Use of configuration incrementing may or may not increase the accuracy of the results. The following guidelines will produce better results when using configuration incrementing:

- The user may run different angles of attack in each case. However, no angle of attack should exceed the upper or lower limit of the angles of attack for which experimental data was input in the first case.
- Experimental data should be input at as many angles of attack as possible.
- The user should remember that the effect of a change in Mach number from case to case is not corrected by inputting experimental data at one Mach number as is required.

NACA

This card defines the NACA airfoil section designation (or supersonic airfoil definition). Note that if airfoil coordinates and the NACA card are specified for the same aerodynamic surface, the airfoil coordinate specification will be used. Therefore, if coordinates have been specified in a previous case and the SAVE option is in effect, the saved namelist must be deleted or the namelist variable SECTYP must be changed for the NACA card to be recognized for that aerodynamic surface. The airfoil designated with this card will be used for all segments and panels of the fin set.

The form of this control card and the required parameters are as follows:

<u>Card Column(s)</u>	<u>Input(s)</u>	<u>Purpose</u>
1 thru 4	NACA	The unique letters NACA designate that an airfoil is to be defined
5	Any delimiter	
6	1,2,3, or 4	Fin set number for which the airfoil designation applies
7	Any delimiter	
8	1,4,5,6,S	Type of NACA airfoil section; 1-series (1), 4-digit (4), 5-digit (5), 6-series (6), or supersonic (S)
9	Any delimiter	
10 thru 80	Designation	Input designation (see Table 6); columns are free-field (blanks are ignored)

Only fifteen (15) characters are accepted in the airfoil designation. The vocabulary consists of the following characters:

0 1 2 3 4 5 6 7 8 9 A , = . -

Any characters input that are not in the vocabulary list will be interpreted as the number zero (0). Table 13 details the restrictions on the NACA designation.

NAMELIST

This control card instructs the program to print all namelist data. This is useful when multiple inputs of the same variable or namelist are used. This control card is effective only for the case in which it appears.

NEXT CASE

This card indicates termination of the case input data and instructs the program to begin case execution. It is required for multiple case "runs". This card must be the last card input for the case.

NOGO

This control card permits the program to cycle through all of the input cases without computing configuration aerodynamics. It can be present anywhere in the input stream and only needs to appear once. This option is useful for performing error checking to insure all cases have been correctly set up.

NO LAT

This control card inhibits the calculation of the lateral-directional derivatives due to sideslip angle, and the roll rate and yaw rate derivatives if the control card DAMP is selected. Large savings in computation time can be realized by using this option. This option is automatically selected when using TRIM.

PART

This control card permits printing of partial aerodynamic output, such as a summary of the normal force and axial force contributors. Partial output of the configuration synthesis methods is only provided if the TRIM option is not selected. Use of this card is equivalent to inputting all PRINT AERO and PRINT GEOM control cards. This control card is effective only for the case in which it appears.

PLOT

A data file for use with a post-processing plotting program is provided when this control card is used. A formatted file is written to tape unit 3 ("for003.dat").

PRESSURES

This control card instructs the program to print the body and fin alone pressure coefficient distributions at supersonic speeds. Only pressure data to 15 degrees angle of attack for bodies and at zero angle of attack for fins are printed. The body pressure output at positive angle of attack is written to tape unit 10 ("for010.dat"). The fin pressure output is written to tape unit 11 ("for011.dat"). The body pressure output and local Mach number at zero angle of attack are written to tape unit 12 ("for012.dat"). This control card is effective only for the case in which it appears.

PRINT AERO name

This control card instructs the program to print the incremental aerodynamics for "name", which can be one of the following:

BODY	for body aerodynamics
FIN1	for FINSET1 aerodynamics
FIN2	for FINSET2 aerodynamics
FIN3	for FINSET3 aerodynamics
FIN4	for FINSET4 aerodynamics
SYNTHS	for configuration synthesis aerodynamics
TRIM	for trim/untrimmed aerodynamics
BEND	for panel bending moments
HINGE	for panel hinge moments
INLET	for inlet aerodynamics

All options are automatically selected when the control card PART is used. Details of the output obtained with these options are presented in Section 4.2. The PRINT AERO control cards are effective only for the case in which they appear.

PRINT GEOM name

This control card instructs the program to print the geometric characteristics of the configuration component "name", which can be one of the following:

BODY	for body geometry
FIN1	for FINSET1 geometry
FIN2	for FINSET2 geometry
FIN3	for FINSET3 geometry
FIN4	for FINSET4 geometry
INLET	for inlet geometry

If PRINT GEOM BODY is selected and the Mach number is greater than 1.2, the body contour coordinates (X,R) used by the program are written to tape unit 9 ("for009.dat"). This contour will contain many additional points in between the user specified input coordinates, and is useful for verifying that the DISCON values have been properly entered.

All options are automatically selected when the control card PART is used. The PRINT control cards are effective only for the case in which they appear.

SAVE

The SAVE card saves namelist inputs from one case to the following case but not for the entire run. This permits the user to build-up or change a complex configuration, case-to-case, by adding new namelist cards without having to re-input namelist cards of the previous case. When changing a namelist that has been saved, the namelist must first be deleted using the delete control card.

The only control card that can be optionally saved, case-to-case, is the NACA card. This control card is effective only for the case in which it appears.

SOSE

The presence of this control card selects the Second-Order Shock Expansion method for axisymmetric bodies at supersonic speeds. SOSE should be selected if any Mach number is higher than 2.0.

SPIN

When the SPIN control card is input, spin and magnus derivatives are computed for body alone. If the configuration being run is a body + fin sets, the spin derivatives are still computed for body alone. A PART or BUILD card must be input for body alone derivatives to be printed out. This control card is effective only for the case in which it appears.

TRIM

This control card causes the program to perform a trim calculation. Component buildup data cannot be dumped if TRIM is selected. The use of this control card is the same as if the namelist TRIM was included except that the defaults for namelist TRIM are used. This control card is effective only for the case in which it appears.

WRITE name, start, end

This control card causes the common block "name" to be printed to tape unit 4 ("for004.dat") using the most recent FORMAT control card. Locations from "start" to "end" are dumped. A complete definition of each common block is provided in Tables 18-26. Multiple WRITE statements may be input, and there is no limit to the number which may be present. The presence of a WRITE will cause the block "name" to be printed for all cases of the run. The output will be in units of feet, pounds, degrees, or degrees Rankine.

Any card with an asterisk (*) in Column 1 will be interpreted as a comment card. This permits detailed documentation of case inputs.

3.3 TYPICAL CASE SET-UP

Figure 16 schematically shows how Missile Datcom inputs are structured. This example illustrates a multiple case job in which case 2 uses part of the case 1 inputs. This is accomplished through use of the SAVE control card. Case 1 is a body-wing-tail configuration; partial output, component buildup data, and a plot file are created. Case 2 uses the body and tail data of case 1 (the wing is deleted using DELETE), specifies panel deflection angles and sets the data required to trim.

There is no limit to the number of cases that can be "stacked" in a single run, provided that no more than 300 namelist inputs are "saved" between cases. If a SAVE control card is not present in a case, all previous case inputs are deleted.

A "configuration incrementing" case set-up is shown in Figure 17. This figure shows the inputs for a three case set-up fin parametric analysis. The first case is the calibration case with the remaining cases being used for the parametric analysis. Therefore, the first case must contain both the INCRMT control card and EXPR namelist. These should only appear in the first case.

Table 1 Namelist Alphanumeric Constants

NAMELIST	PERMITTED ALPHANUMERIC CONSTANTS	CONVERTED VALUE
(ALL)	UNUSED	1.0E-30 (initialized value)
REFQ	TURB NATURAL	0. 1.
AXIBOD Or ELLBOD	CONICAL CONE OGIVE POWER HAACK KARMAN	0. 0. 1. 2. 3. 4.
PROTUB	VCYL HCYL LUG SHOE BLOCK FAIRING	1. 2. 3. 4. 5. 6.
FINSETn	HEX NACA ARC USER	0. 1. 2. 3.
INLET	2DSIDE AXI 2DTOP	1. 2. 3.
EXPR	BODY F1 F2 F3 F4 BF1 BF12 BF123 BF1234	1. 2. 3. 4. 5. 6. 7. 8. 9.

Table 2 Equivalent Sand Roughness

TYPE OF SURFACE	EQUIVALENT SAND ROUGHNESS k (INCHES)	RHR
Aerodynamically Smooth	0.0	0.0
Polished Metal or Wood	0.00002 to 0.00008	6 to 26
Natural Sheet Metal	0.00016	53
Smooth Matte Paint, Carefully Applied	0.00025	83
Camouflage Paint, Average Application	0.00040	133
Camouflage Paint, Mass Production Spray	0.0012	400
Dip Galvanized Metal Surface	0.006	2000
Natural Surface of Cast Iron	0.01	3333

Preferred RHR Values

APPLICATION	RHR
Steel Structural Parts	250
Aluminum and Titanium Structural Parts	125
Close Tolerance Surfaces	63
Seals	32

NAMELIST FLTCON

VARIABLE NAME	ARRAY SIZE	DEFINITION	UNITS**	DEFAULT
NALPHA	-	Number of angles of attack (must be > 1)	-	-
ALPHA	20	Angle of attack or total angle of attack	deg	-
BETA	-	Sideslip angle	deg	0.
PHI	-	Aerodynamic roll angle	deg	0.
NMACH	-	Number of Mach numbers or velocities	-	-
MACH*	20	Mach numbers	-	-
ALT*	20	Altitudes	L	0.
REN*	20	Reynolds numbers per unit length	1/L	-
VINF*	20	Freestream velocities	L/sec	-
TINF*	20	Freestream static temperatures	deg	-
PINF*	20	Freestream static pressures	F/(L*L)	-

* Any of the following combinations satisfy the minimum requirements for calculating atmospheric conditions (Mach and Reynolds number):

1. MACH and REN
2. MACH and ALT
3. MACH and VINF and TINF
4. VINF and ALT
5. VINF and TINF and PINF

** Lengths are in feet for English units and meters for metric units.

Table 3 Flight Condition Inputs

NAMELIST REFQ

VARIABLE NAME	ARRAY SIZE	DEFINITION	UNITS	DEFAULT
SREF	-	Reference area	L*L	*
LREF	-	Longitudinal reference length	L	**
LATREF	-	Lateral reference length	L	LREF
XCG	-	Longitudinal position of C.G. (+aft)	L	0.
ZCG	-	Vertical position of C.G. (+up)	L	0.
BLAYER	-	Boundary layer type: TURB for fully turbulent NATURAL for natural transition	-	TURB
ROUGH***	-	Surface roughness height	L	0.
RHR***	-	Roughness Height Rating	-	0.
SCALE	-	Vehicle scale factor	-	1.

* Default is maximum body cross-sectional area. If no body is input, default is maximum fin panel area.

** Default is maximum body diameter. If no body is input, default is fin panel mean geometric chord.

*** Either ROUGH or RHR can be used. If ROUGH is used, the units must be inches (for english) or centimeters (for metric).

Table 4 Reference Quantity Inputs

NAMELIST AXIBOD
(Option 1 Inputs)

VARIABLE NAME	ARRAY SIZE	DEFINITION	UNITS	DEFAULT
XO or X0	-	Longitudinal coordinate of nose tip	L	0.
TNOSE	-	Type of nose shape: CONICAL or CONE (cone) OGIVE (tangent ogive)* POWER (power law) HAACK (L-V constrained) KARMAN (L-D constrained)	-	OGIVE
POWER	-	Exponent, n, for power law shape: $(r/R)=(x/L)^n$	-	0.
LNOSE	-	Nose length	L	-
DNOSE	-	Nose diameter at base	L	1.
BNOSE	-	Nose bluntness radius or radius of truncation	L	0.
TRUNC	-	Truncation flag: .TRUE. if nose is truncated .FALSE. if nose is not truncated	-	.FALSE.
LCENTR	-	Centerbody length	L	0.
DCENTR	-	Centerbody diameter at base	L	DNOSE
TAFT	-	Type of afterbody shape: CONICAL or CONE (cone) OGIVE (tangent ogive)	-	CONICAL
LAFT	-	Afterbody length	L	0.
DAFT	-	Afterbody diameter at base (must be > 0. And not equal to DCENTR)	L	-
DEXIT	-	Nozzle diameter for base drag calculation DEXIT not defined gives zero base drag DEXIT = 0. Gives "full" base drag DEXIT= exit gives base drag of annulus around exit only	L	-
BASE*	-	Flag for base plume interaction: .TRUE. for plume calculations .FALSE. for no plume calculations	-	.FALSE.
BETAN**	-	Nozzle exit angle	deg	-
JMACH**	20***	Jet Mach number at nozzle exit	-	-
PRAT**	20***	Jet/freestream static pressure ratio	-	-
TRAT**	20***	Jet/freestream stagnation temperature ratio	-	-

- * A secant ogive cannot be defined. It is recommended that Option 2 be used for a secant ogive or that the nose be approximated with a POWER nose.
- ** Only required if base plume interaction calculations are desired.
- *** JMACH, PRAT and TRAT must be specified for each freestream Mach number or velocity input in Namelist \$FLTCN.

Table 5 Axisymmetric Body Geometry Inputs - Option 1

NAMELIST AXIBOD
(Option 2 Inputs)

VARIABLE NAME	ARRAY SIZE	DEFINITION	UNITS	DEFAULT
XO or X0	-	Longitudinal coordinate of nose tip	L	0.
NX	-	Number of input stations ($2 < NX < 50$)	-	-
X*	50	Longitudinal coordinates X(NX) must be the end of the body	L	-
R	50	Radius at each X station	L	-
DISCON	20	Indices of X stations where the surface slope Is discontinuous. Example: X(1)=0.,4.,8.,12.,16.,20., DISCON=3., Defines a discontinuity at X=8. (third value)	-	-
BNOSE	-	Nose bluntness radius or radius of truncation	L	0.
TRUNC	-	Truncation flag: .TRUE. if nose is truncated .FALSE. if nose is not truncated	-	.FALSE.
DEXIT	-	Nozzle diameter for base drag calculation DEXIT not defined gives zero base drag DEXIT = 0. Gives "full" base drag DEXIT= exit gives base drag of annulus Around exit only	L	-

* If the nose is spherically blunted and the Mach number is greater than 1.2, the first five points must be located on the hemispherical cap, and the sixth point must be aft of the cap.

Table 6 Axisymmetric Body Geometry Inputs - Option 2

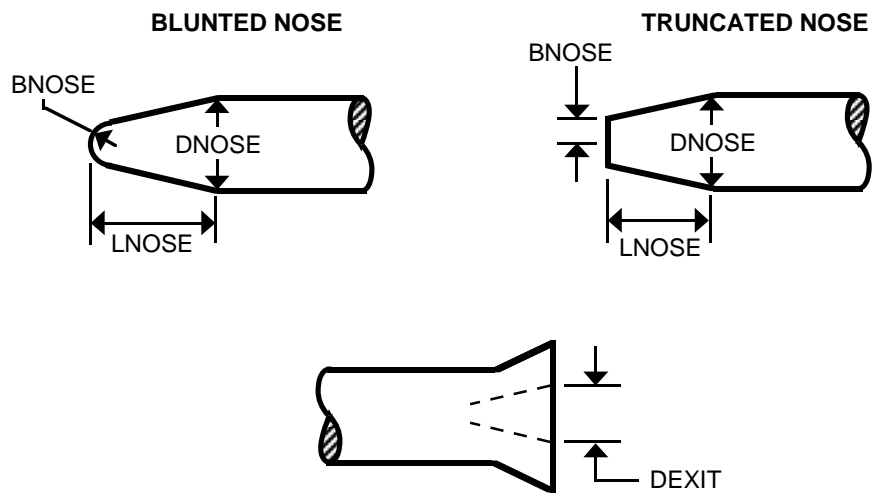
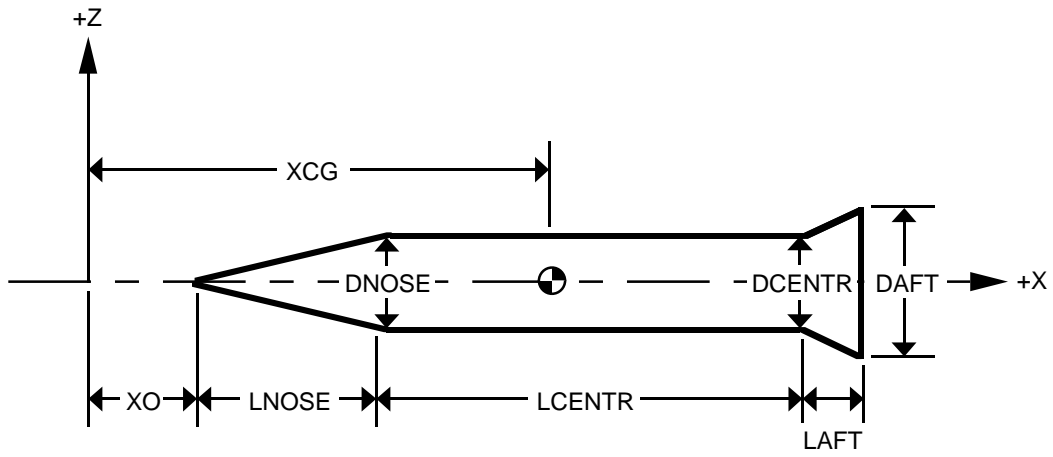
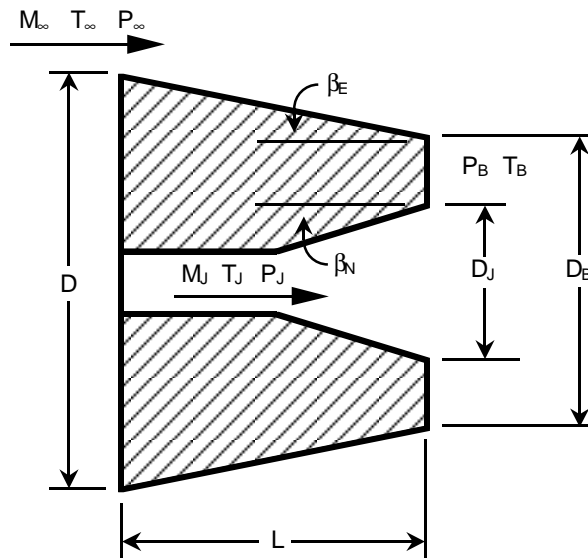

Figure 1 Body Geometry Inputs



Input Parameter	Symbol	Min. Value	Max. Value
Boattail shape	--	Cylinder, Cone, Ogive	
Boattail fineness ratio	L/D	0	2
Boattail terminal angle	β_E	0°	12°
Jet pressure ratio	P_J/P	0	10
Freestream Mach number	M	2	5
Angle of Attack	α	0°	8°
Jet Mach number	M_J	$M - 1$	$M + 1$
Nozzle terminal angle	β_N	5°	25°
Jet diameter ratio	D_J/D_B	0.80	0.95
Jet temperature ratio	T_{tj}/T_t	4	10

Note; If input parameter is not between minimum and maximum value the code will extrapolate

Figure 2 Base-Jet Plume Interaction Parameters

NAMELIST ELLBOD
(OPTION 1 INPUTS)

VARIABLE NAME	ARRAY SIZE	DEFINITION	UNITS	DEFAULT
XO or X0	-	Longitudinal coordinate of nose tip	L	0.
TNOSE	-	Type of nose shape: CONICAL or CONE (cone) OGIVE (tangent ogive)* POWER (power law) HAACK (L-V constrained) KARMAN (L-D constrained)	-	OGIVE
POWER	-	Exponent, n, for power law shape: $(r/R)=(x/L)^n$	-	0.
LNOSE	-	Nose length	L	-
WNOSE	-	Nose width at base	L	1.
ENOSE	-	Ellipticity at nose base (height/width)	-	1.0
BNOSE	-	Nose bluntness radius or radius of truncated nose	L	0.
TRUNC	-	Truncation flag: .TRUE. if nose is truncated .FALSE. if nose is not truncated	-	.FALSE.
LCENTR	-	Centerbody length	L	0.
WCENTR	-	Centerbody width at base	L	WNOSE
ECENTR	-	Ellipticity at centerbody base (height/width)	-	1.0
TAFT	-	Type of afterbody shape: CONICAL or CONE (cone) OGIVE (tangent ogive)	-	CONICAL
LAFT	-	Afterbody length	L	0.
WAFT	-	Afterbody diameter at base (must be > 0. And not equal to WCENTR)	L	-
EAFT	-	Ellipticity at aft body base (height/width)	-	1.0
DEXIT	-	Nozzle diameter for base drag calculation DEXIT not defined gives zero base drag DEXIT = 0. Gives "full" base drag DEXIT= exit gives base drag of annulus Around exit only	L	-

Table 7 Elliptical Body Geometry Inputs - Option 1

NAMELIST ELLBOD
(Option 2 Inputs)

VARIABLE NAME	ARRAY SIZE	DEFINITION	UNITS	DEFAULT
XO or X0	-	Longitudinal coordinate of nose tip	L	0.
NX	-	Number of input stations ($2 < NX < 50$)	-	-
X	50	Longitudinal coordinates X(NX) must be the end of the body	L	-
H*	50	Body half-height at each X station		
W*	50	Body half-width at each X station	L	-
ELLIP*	50	Body height to width ratio at each X station	-	1.0
DISCON	20	Indices of X stations where the surface slope is discontinuous. Example: X(1)=0.,4.,8.,12.,16.,20., DISCON=3., Defines a discontinuity at X=8. (third value)	-	-
BNOSE	-	Nose bluntness radius or radius of truncatoin	L	0.
TRUNC	-	Truncation flag: .TRUE. if nose is truncated .FALSE. if nose is not truncated	-	.FALSE.
DEXIT	-	Nozzle diameter for base drag calculation DEXIT not defined gives zero base drag DEXIT = 0. Gives "full" base drag DEXIT= exit gives base drag of annulus Around exit only	L	-

* One of the following combinations is required:

1. W and H
2. W and ELLIP
3. H and ELLIP

Table 8 Elliptical Body Geometry Inputs - Option 2

OPTION 1

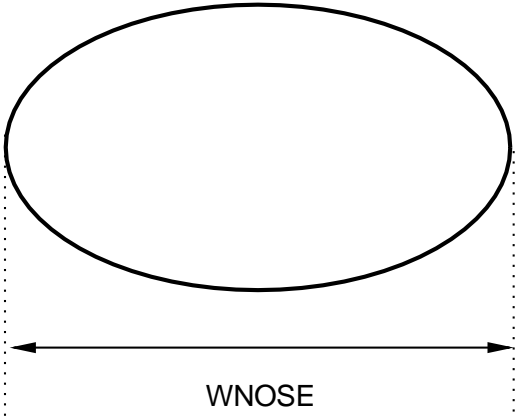

OPTION 2

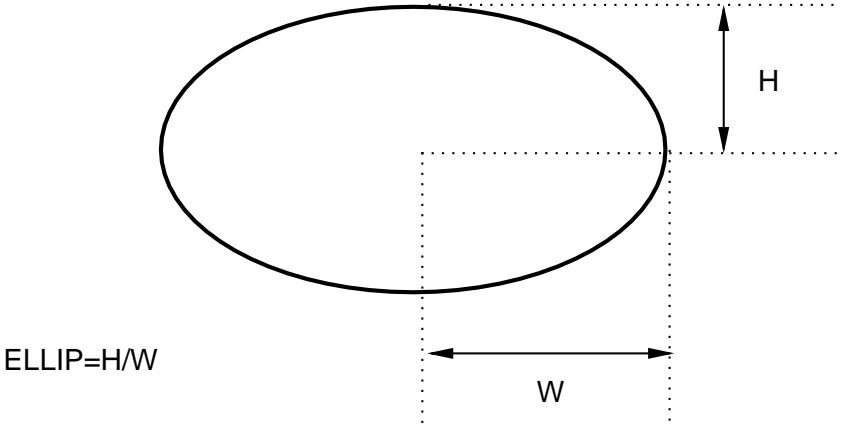

ELLIP=H/W

NOTE: Option 1 input WNOSE is TOTAL Width, Option 2 input W is HALF width

Figure 3 Elliptical Body Geometry

NAMELIST PROTUB

VARIABLE NAME	ARRAY SIZE	DEFINITION	UNITS	DEFAULT
NPROT	-	Number of protuberance sets (20 maximum)	-	0.
PTYPE	20	Protuberance set type: VCYL (cylinder perpendicular to flow) HCYL (cylinder aligned with flow) BLOCK FAIRING (streamline half body) LUG (launch lug)** SHOE (launch shoe)**	-	-
XPROT	20	Longitudinal distance from missile nose to Protuberance set	L	-
NLOC*	20	Number of protuberances in set	-	0.
LPROT	100	Length of protuberance	L	-
WPROT	100	Width of protuberance	L	-
HPROT	100	Height of protuberance	L	-
OPROT	100	Vertical offset of protuberance	L	0.

* NLOC is number of identical protuberances (same size and shape) located around the body at the same axial station.

** LUG type has 4 members. SHOE type has three members. LPROT, WPROT, HPROT, and OPROT must be specified for each member.

Table 9 Protuberance Inputs

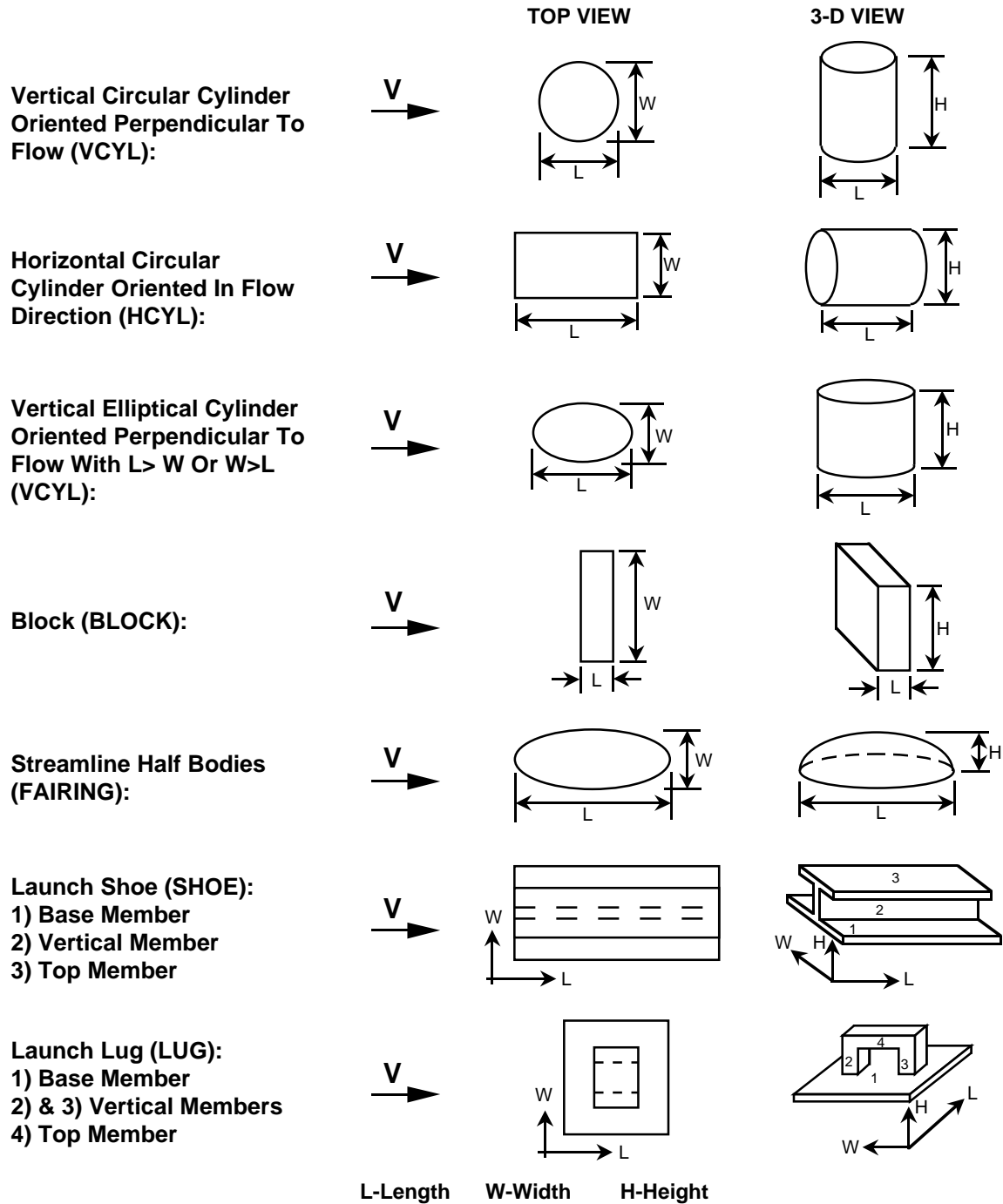

Note; Length, width, height, and offset must be input for each member of launch lug and launch shoe types

Note; Offset is the perpendicular distance from the missile mold line to the bottom of the protuberance or protuberance member

Figure 4 Protuberance Shapes Available

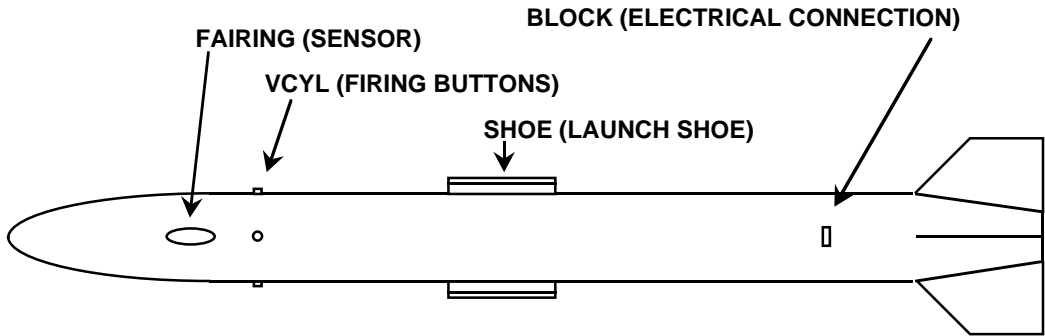

```

CASEID PROTUBERANCE EXAMPLE CASE
DIM IN
NO LAT
$REFQ XCG=39.0,$
$FLTCN NMACH=3.,MACH=0.4,0.8,2.0,
REN=3.E06,3.E06,3.E06,ALT=0.0,
NALPHA=5.,ALPHA=-8.,-4.,0.,4.,8.,$
$AXIBOD TNOSE=OGIVE,LNOSE=12.0,DNOSE=12.0,
LCENTR=54.0,DCENTR=12.0,
TAFT=CONE,LAFT=12.0,DAFT=6.0,DEXIT=5.0,$
$PROTUB NPROT=4.,
PTYPE=FAIRING,VCYL,SHOE,BLOCK,
XPROT=14.,22.,39.,56.,
NLOC=2.,4.,2.,1.,
LPROT=5.,1.,10.,10.,10.,0.5,
WPROT=2.,1.,4.,0.25,1.,1.,
HPROT=2.,0.5,0.1,0.75,0.25,0.25,
OPROT=0.,0.,0.,0.1,0.85,0.,$
$FINSET1 SSPAN=0.0,9.0,CHORD=14.0,8.0,
XLE=64.0,SWEEP=0.0,STA=1.0,NPANEL=4.,
PHIF=45.,135.,225.,315.,$
PRINT GEOM BODY
PRINT AERO BODY
SAVE
NEXT CASE

```

NOTE; Length, Width, and Height is input for each member of the launch shoe

Figure 5 Protuberance Example Input File

NAMELIST FINSETn
(NOMINAL INPUTS)

VARIABLE NAME	ARRAY SIZE	DEFINITION	UNITS	DEFAULT
SECTYP	-	Type of airfoil section: HEX (hexagonal section, Table 11) ARC (curcular arc section, Table 11) USER (used defined section coordinates, Table 12) NACA (requires NACA control card, Table 13)	-	HEX
SSPAN	10	Semi-span locations. To automatically place fin On body moldline, use SSPAN(1)=0.0 with other values relative to fin root chord.	L	-
CHORD	10	Panel chord at each semi-span location	L	-
XLE	10	Distance from missile nose to chord leading edge At each span location. Specify only XLE(1) if using SWEEP to define planform.	L	0.0
SWEEP	10	Sweepback angle at each span station.	deg	0.0
STA	10	Chord station used in measuring sweep: STA=0.0 is leading edge STA=1.0 is trailing edge	-	1.0
LER	10	Leading edge radius at each span station. Not required if SECTYP=NACA	L	0.0
NPANEL	8	Number of panels in fin set (1-8)	-	4
PHIF	8	Roll angle of each fin measured clockwise from top vertical center looking forward	deg	*
GAM	8	Dihedral of each fin, positive when PHIF is increased, see Fig. 8.	Deg	0.0
CFOC	8	Flap chord to fin chord ratio at each span station	-	1.0

* If PHIF not used, panels will be evenly spaced around the body.

Table 10 Fin Geometry Inputs

Multi-Segment Fin Placement

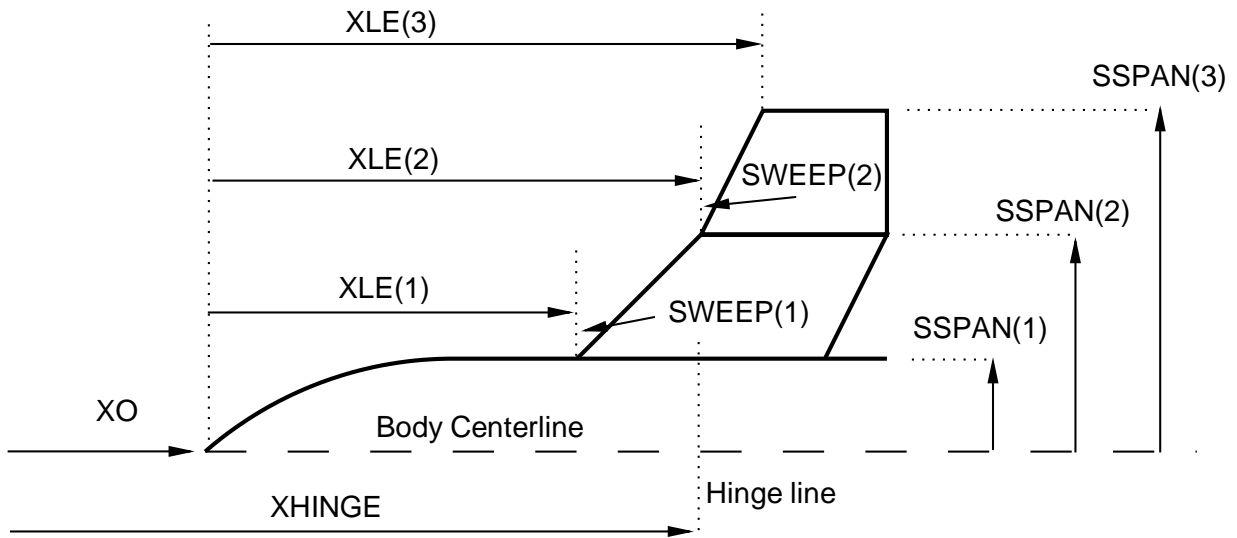

NOTE 1: XLE measured from body nose, XHINGE measured from origin

NOTE 2: Define either XLE(1) with various values of SWEEP
OR multiple values of XLE with no SWEEP

Varying Body Radius Placement

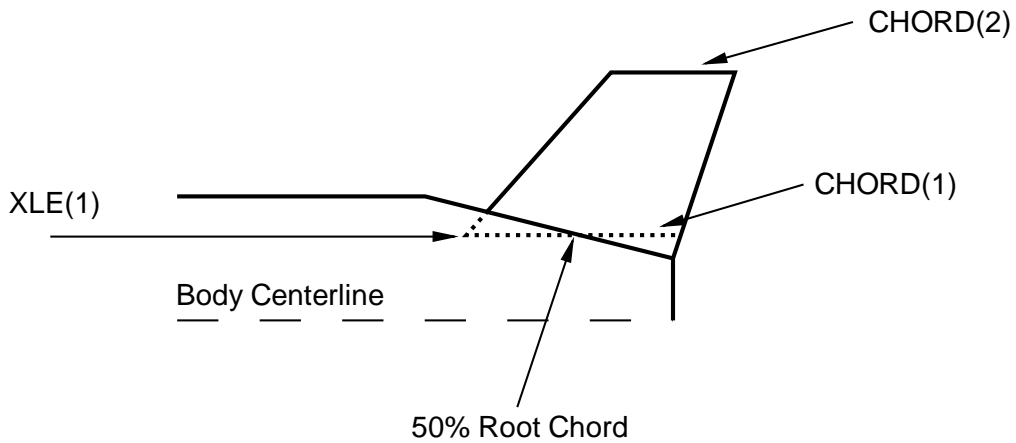
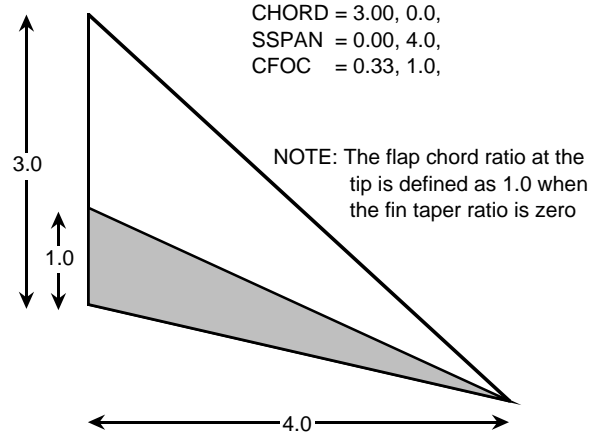
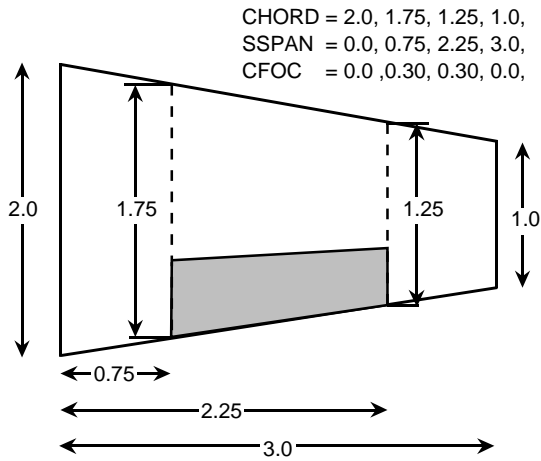
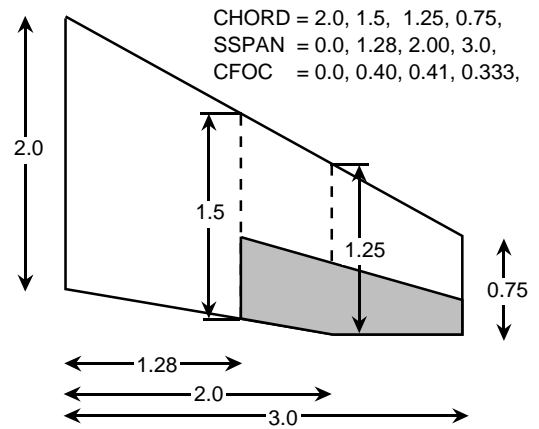
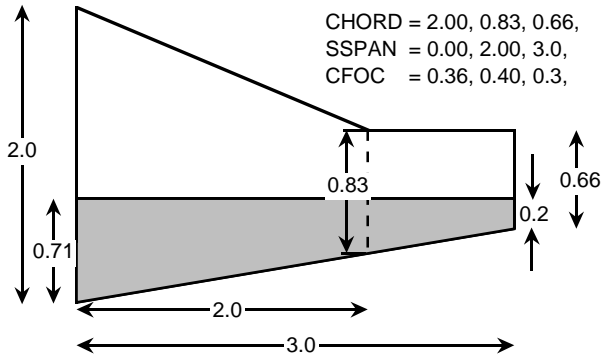
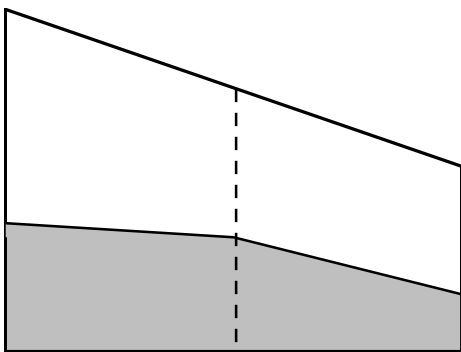

Figure 6 Fin Placement on Body



Valid Trailing Edge Device Definitions



• Cranked Hinge Line Is Invalid

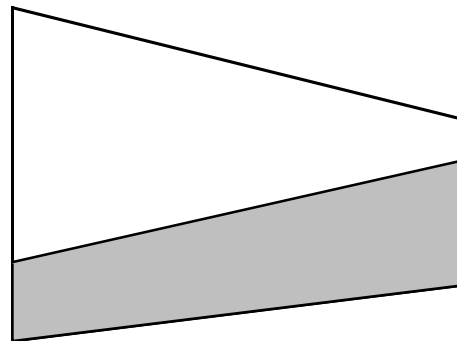

• Trailing Edge Device With Taper Ratio Greater Than One Is Invalid

Invalid Trailing Edge Device Definitions

Figure 7 Definition Of Plain Trailing Edge Devices

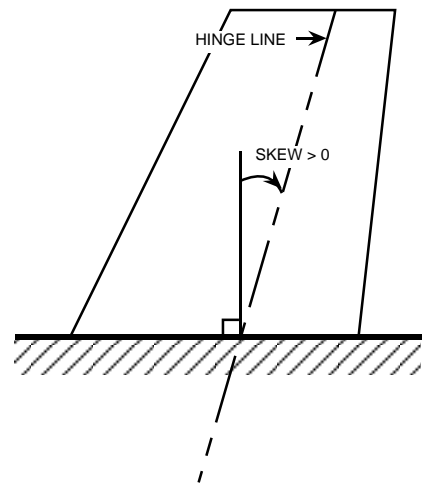
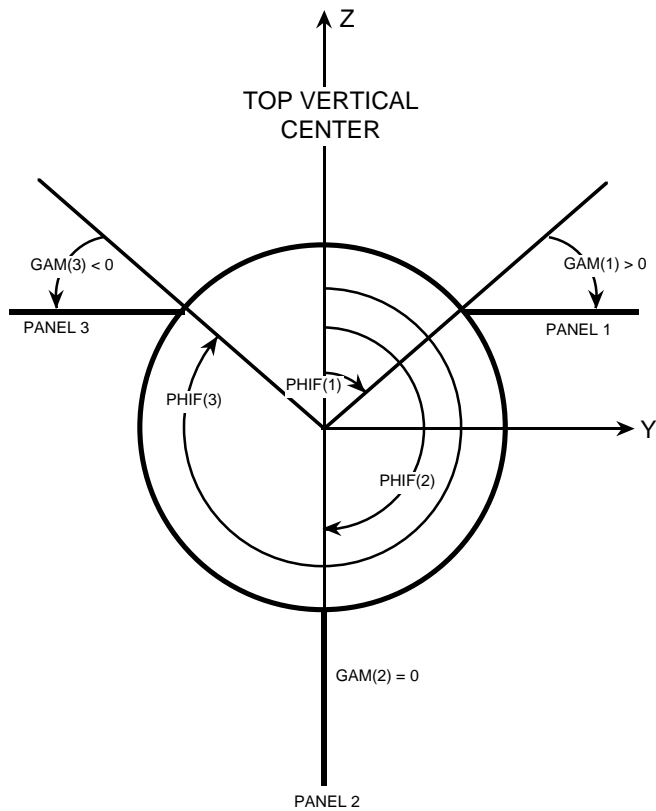
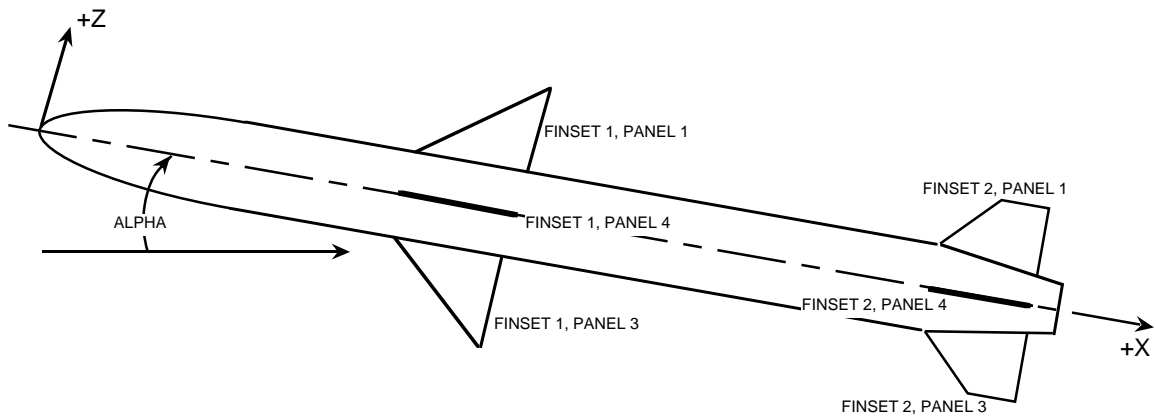

**VIEW LOOKING FORWARD
FROM BEHIND MISSILE**

Figure 8 Fin Numbering and Orientation

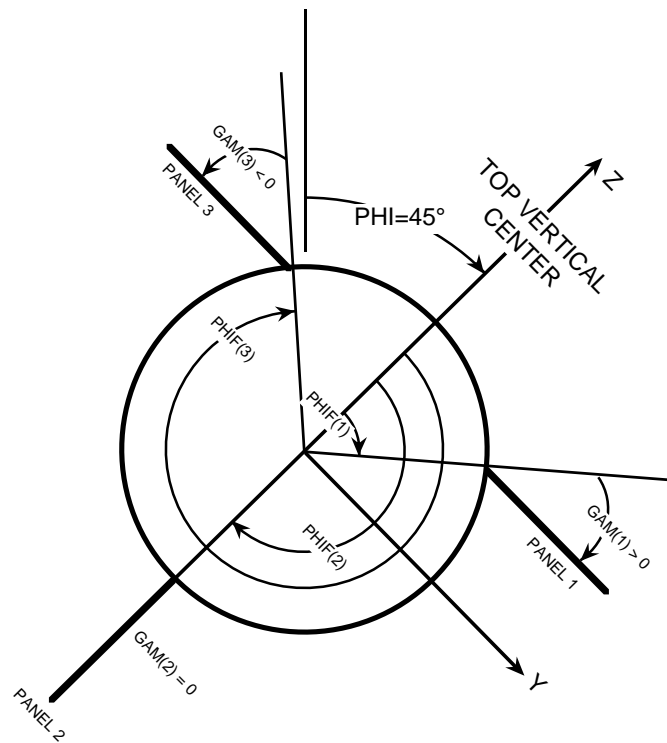

**VIEW LOOKING FORWARD
FROM BEHIND MISSILE**

**PHI IS THE BODY ROLL ANGLE
PHIF IS THE FIN PANEL ROLL ANGLE**

Figure 9 Roll Attitude vs Fin Orientation

NAMELIST FINSETn
(SECTYP= HEX or ARC inputs)

VARIABLE NAME	ARRAY SIZE	DEFINITION	UNITS	DEFAULT
ZUPPER	10	Thickness to chord ratio of upper surface. Input separate value for each span station.	-	0.025
ZLOWER	10	Thickness to chord ratio of lower surface. Input separate value for each span station.	-	ZUPPER
LMAXU	10	Fraction of chord from section leading edge to maximum thickness of upper surface. Input separate value for each span station.	-	0.5
LMAXL	10	Fraction of chord from section leading edge to maximum thickness of lower surface. Input separate value for each span station.	-	LMAXU
LFLATU	10	Fraction of chord of constant thickness Section of upper surface. Input separate value for each span station.	-	0.
LFLATL	10	Fraction of chord of constant thickness Section of lower surface. Input separate value for each span station.	-	LFLATU

Table 11 Fin Geometry Inputs - HEX or ARC Airfoils

NAMELIST FINSETn
(SECTYP= USER inputs)

VARIABLE NAME*	ARRAY SIZE	DEFINITION	UNITS	DEFAULT
XCORD	50	Chord station, fraction of chord from Leading edge	-	-
MEAN	50	Distance between the mean line and chord at each XCORD station in fraction of chord	-	-
THICK	50	Thickness to chord ratio at each XCORD Station	-	-
YUPPER	50	Upper surface coordinates at each XCORD Station in fraction of chord	-	-
YLOWER	50	Lower surface coordinates at each XCORD Station in fraction of chord	-	-

- * One of the following combinations is required:
1. XCORD, MEAN, and THICK
 2. XCORD, YUPPER, and YLOWER

Table 12 Fin Geometry Inputs - User Airfoils

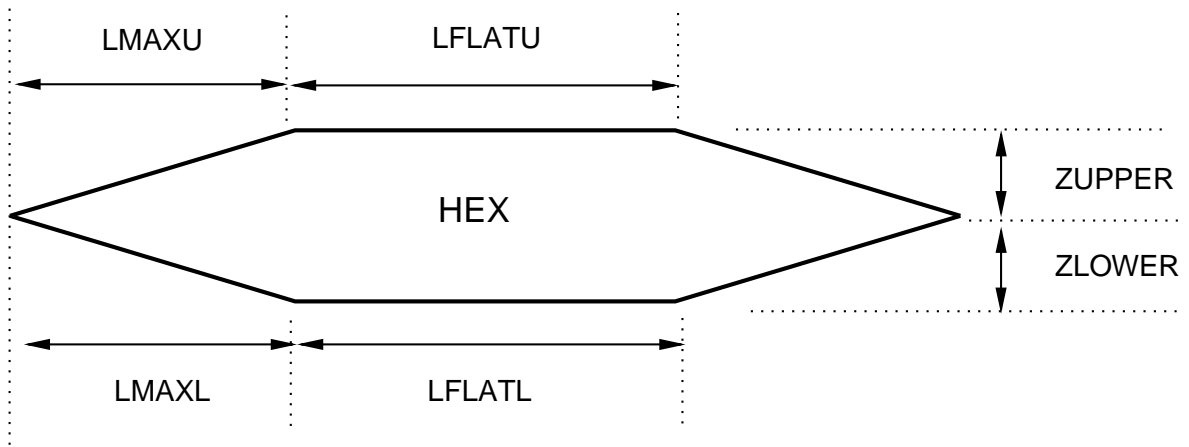

NOTE: All parameters must be input at each span station

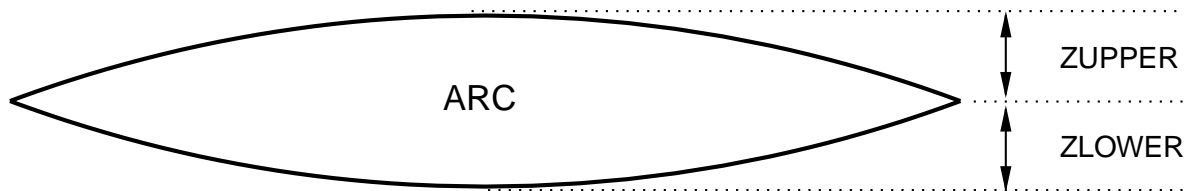

NOTE: ARC section only allows ZUPPER and ZLOWER

Figure 10 HEX and ARC Airfoil Input

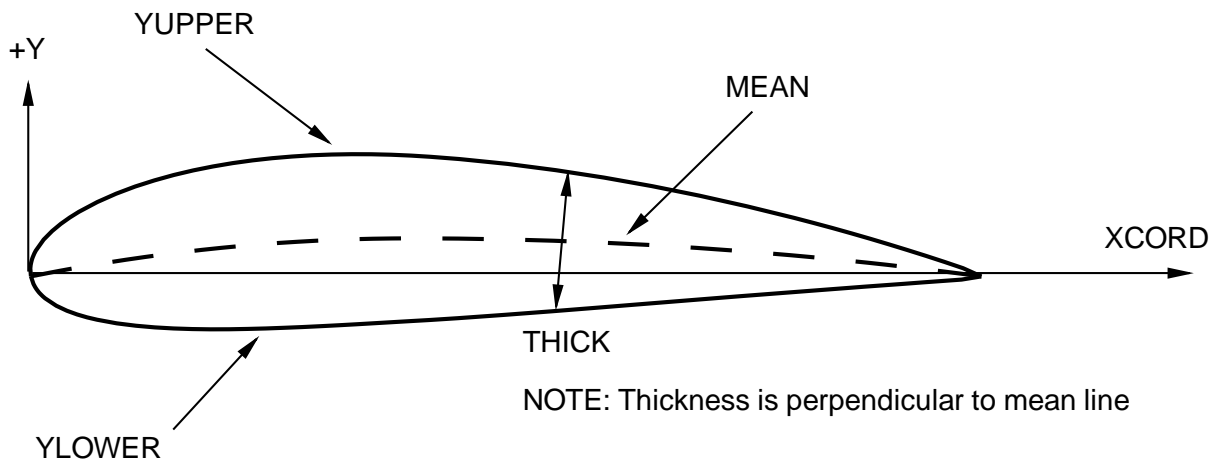

Figure 11 USER Airfoil Input

Table 13 Airfoil Designation Using the NACA Control Card

NACA SERIES	DIGIT	SERIES DESIGNATION RULES	SAMPLES (fin set and series follow NACA)
4 Series	1	Maximum value of mean line ordinate, % chord	NACA-1-4-0008 NACA-2-4-2412.75
	2	Distance to maximum camber point, tenths of chord	
	3,4	Maximum thickness, % chord*	
Modified 4 Series	1-4	Same as 4 Series	NACA-1-4-0012.25-62 NACA-2-4-4410-35 NACA-3-4-2204-04
	5	Dash (-)	
	6 7	Leading edge radius, sharp: 0, normal radius: 6 Position of maximum thickness, tenths of chord, must be 2,3,4,5, or 6	
5 Series	1	2/3 of design lift coefficient in tenths, (2 indicates design C_l of 0.3)	NACA-1-5-23012 NACA-2-5-42008.33 NACA-3-5-12015
	2,3	Twice distance to maximum camber point, % chord, (20 gives maximum camber at 10% chord)	
	4,5	Maximum thickness, % chord*	
Modified 5 Series	1-5	Same as 5 Series	NACA-1-5-23012-32 NACA-2-5-21018.5-05 NACA-3-5-22406-63
	6	Dash (-)	
	7 8	Leading edge radius, sharp: 0, normal radius: 6 Position of maximum thickness, tenths of chord, must be 2,3,4,5 or 6	
1 Series	1	Series designation	NACA-1-1-16-212.25 NACA-2-1-18-006 NACA-3-1-19-110.5
	2	Distance to minimum pressure point, tenths of chord, must be 6,8, or 9	
	3	Dash (-)	
	4	Design lift coefficient in tenths	
	5,6	Maximum thickness, % chord*	
6 Series	1	Series designation	NACA-1-6-64-005 NACA-2-6-61-205 A=0.6 NACA-3-6-65A010.75
	2	Distance to minimum pressure point, tenths of chord	
	3	Dash (-): conventional section "A": section straight from 80% chord to TE	
	4	Design lift coefficient in tenths	
	5,6	Maximum thickness, % chord*	
	7	Optional mean line parameter (A=xx), must be decimal between 0.1 and 1.0, default is 1.0	
Supersonic	1	Type: 1=diamond, 2=circular arc, 3=hexagonal	NACA-1-S-3-25-5-50 NACA-2-S-2-66.7-7.5 NACA-3-S-1-45.5-6.8
	2	Distance to maximum thickness, % chord*	
	3	Maximum thickness, % chord*	
	4	Length of constant thickness section, % chord* (hexagonal section only)*	

* Thickness can be expressed to nearest 0.01% chord for 1,4,5, and 6 series and nearest 0.1% chord for supersonic series

NAMELIST DEFLCT

VARIABLE NAME	ARRAY SIZE	DEFINITION	UNITS	DEFAULT
DELTA1	8	Deflection angles for each panel in fin set 1	deg	0.
DELTA2	8	Deflection angles for each panel in fin set 2	deg	0.
DELTA3	8	Deflection angles for each panel in fin set 3	deg	0.
DELTA4	8	Deflection angles for each panel in fin set 4	deg	0.
XHINGE	4	Position of the panel hinge line for Each fin set, measured from the coordinate system origin. XHINGE is NOT measured from the Body nose unless XO=0.	L	XO+XLE+CR/2*
SKEW	4	Hinge line sweepback for each fin set	deg	0.

* Default is at one-half of the exposed root chord, as measured from the coordinate system origin.

NOTE: A POSITIVE DEFLECTION ANGLE PRODUCES A NEGATIVE
BODY AXIS ROLLING MOMENT AT ZERO ANGLE OF ATTACK

Table 14 Panel Deflection Inputs

NAMELIST TRIM

VARIABLE NAME	ARRAY SIZE	DEFINITION	UNITS	DEFAULT
SET	-	Fin set to be used for trim	-	1.
PANL1	-	.TRUE. if panel to be used	-	.FALSE.
PANL2	-	.TRUE. if panel to be used	-	.FALSE.
PANL3	-	.TRUE. if panel to be used	-	.FALSE.
PANL4	-	.TRUE. if panel to be used	-	.FALSE.
PANL5	-	.TRUE. if panel to be used	-	.FALSE.
PANL6	-	.TRUE. if panel to be used	-	.FALSE.
PANL7	-	.TRUE. if panel to be used	-	.FALSE.
PANL8	-	.TRUE. if panel to be used	-	.FALSE.
DELMIN*	-	Minimum negative deflection	deg	-25.
DELMAX*	-	Maximum positive deflection	deg	+20.
ASYM	8	Flag to reverse sign convention for Fin deflection of specified panel	-	.FALSE.

* Both DELMIN and DELMAX must be specified.

Table 15 Trim Inputs

NAMELIST INLET

VARIABLE NAME	ARRAY SIZE	DEFINITION	UNITS	DEFAULT
NIN	-	Number of inlets (maximum 20)	-	-
INTYPE	-	Type of inlet: 2DTOP (top mounted 2-D) 2DSIDE (side mounted 2-D) AXI (axisymmetric)	-	-
XINLT	-	Longitudinal distance from nose tip to inlet leading edge	L	-
XDIV	-	Longitudinal distance from inlet leading edge to diverter leading edge	L	-
HDIV	-	Diverter height at leading edge. HDIV=0 defines conformal inlet. HDIV<0 defines semi-submerged inlet. (see Fig. 15)	L	-
LDIV	-	Length of diverter	L	-
PHI	20	Inlet roll orientations measured clockwise from top vertical center looking forward (same as fin convention)	deg	-
X*	5	Inlet longitudinal positions relative to inlet Leading edge	L	-
H*	5	Inlet heights at the longitudinal positions. Not required if INTYPE=AXI	L	-
W*	5	Inlet widths at the longitudinal positions if INTYPE=2DTOP or 2DSIDE. Inlet diameters if INTYPE=AXI	L	-
COVER	-	Flag for covered inlet: .TRUE. (inlet covered) .FALSE. (inlet open)	-	.FALSE.
RAMP	-	External compression inlet ramp angle	deg	-
ADD	-	Flag for inlet additive drag: .TRUE. (calculate additive drag) .FALSE. (do not calculate)	-	.FALSE.
MFR	20	Mass flow ratio for each Mach number in Namelist \$FLTCON. 0.0 <MFR <1.0. Only required if ADD=.TRUE.	-	-

* Specify X, H, and W at five inlet locations as shown in Figures 12-14. (1) leading edge, (2) cowl lip, (3) midbody start, (4) boattail start, and (5) boattail end. The inlet must be boattailed, meaning $H(5)*W(5) < H(4)*W(4)$ for 2D inlets, or $W(5) < W(4)$ for axisymmetric inlets.

Table 16 Inlet Geometry Inputs

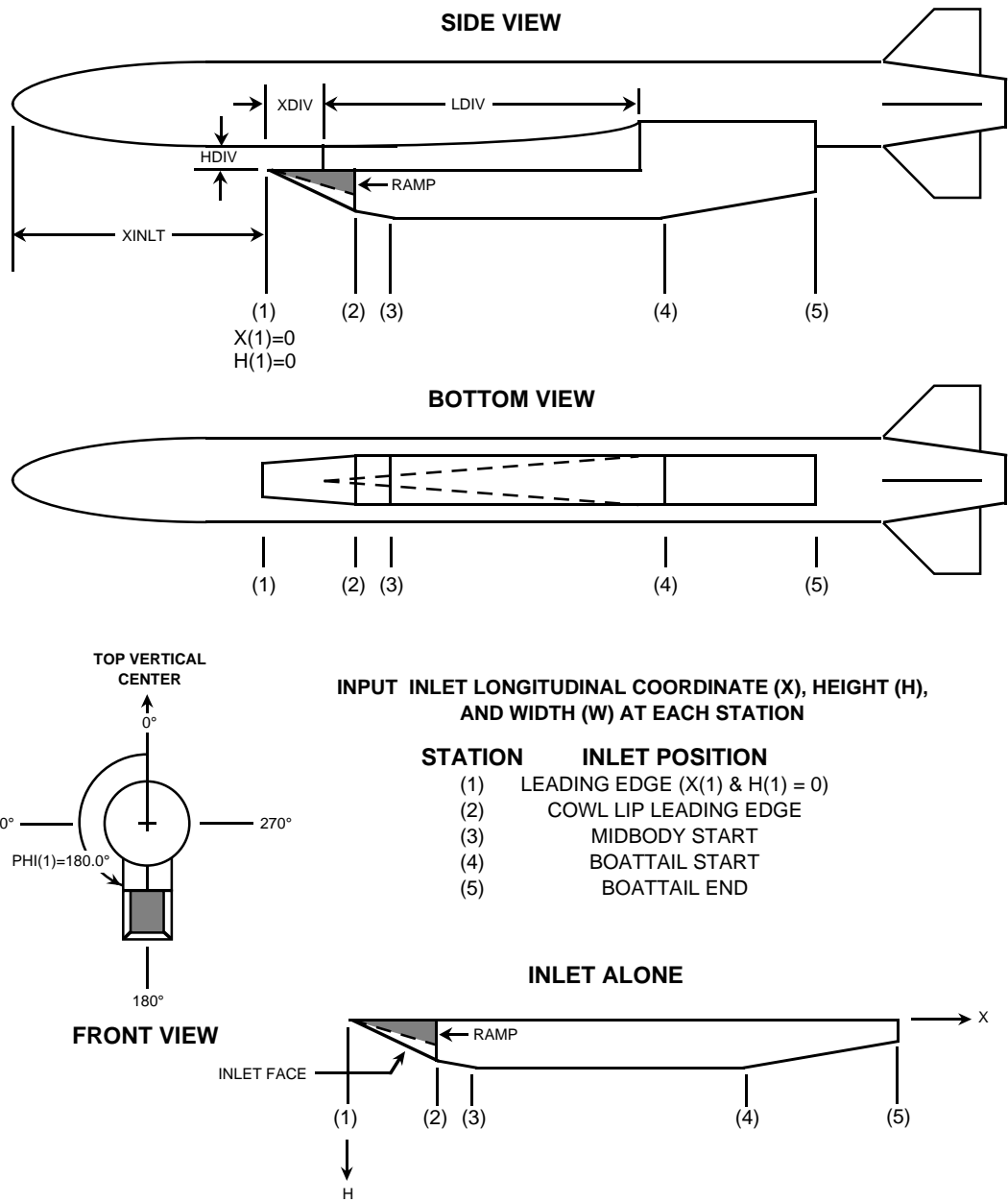
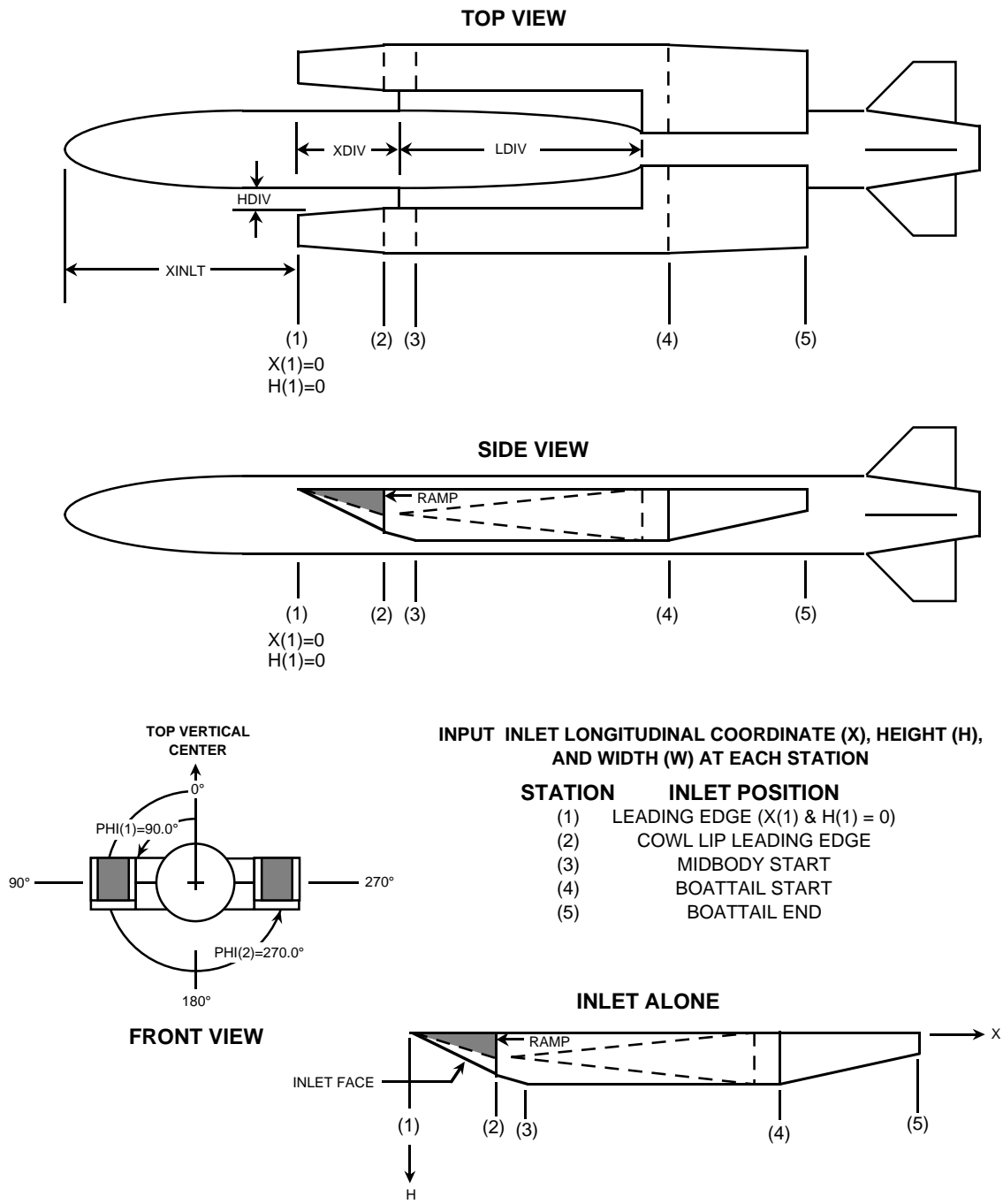

Figure 12 Top-Mounted 2-D Inlet/Diverter Geometry



INPUT INLET LONGITUDINAL COORDINATE (X), HEIGHT (H), AND WIDTH (W) AT EACH STATION

STATION	INLET POSITION
(1)	LEADING EDGE (X(1) & H(1) = 0)
(2)	COWL LIP LEADING EDGE
(3)	MIDBODY START
(4)	BOATTAIL START
(5)	BOATTAIL END

- NOTES;**
- INLET ROLL ORIENTATION IS SAME CONVENTION AS FIN ROLL ORIENTATION.
 - RAMP IS THE EXTERNAL COMPRESSION RAMP ANGLE (SHOWN SHADED IN THE SIDE VIEW)
 - HEIGHT OF THE DIVERTER IS SPECIFIED AT THE DIVERTER LEADING EDGE
 - THE DIVERTER WIDTH IS EQUAL TO THE INLET WIDTH AT LDIV
 - IF INLET IS COVERED (COVER=.TRUE.) A PLUG IS PLACED BETWEEN STATIONS 1 AND 2 FLUSH WITH THE INLET FACE

Figure 13 Side-Mounted 2-D Inlet/Diverter Geometry

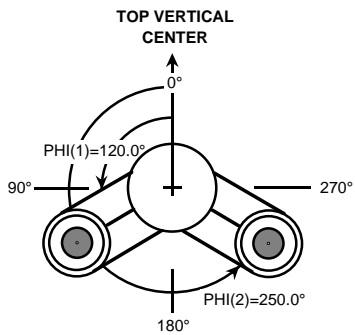
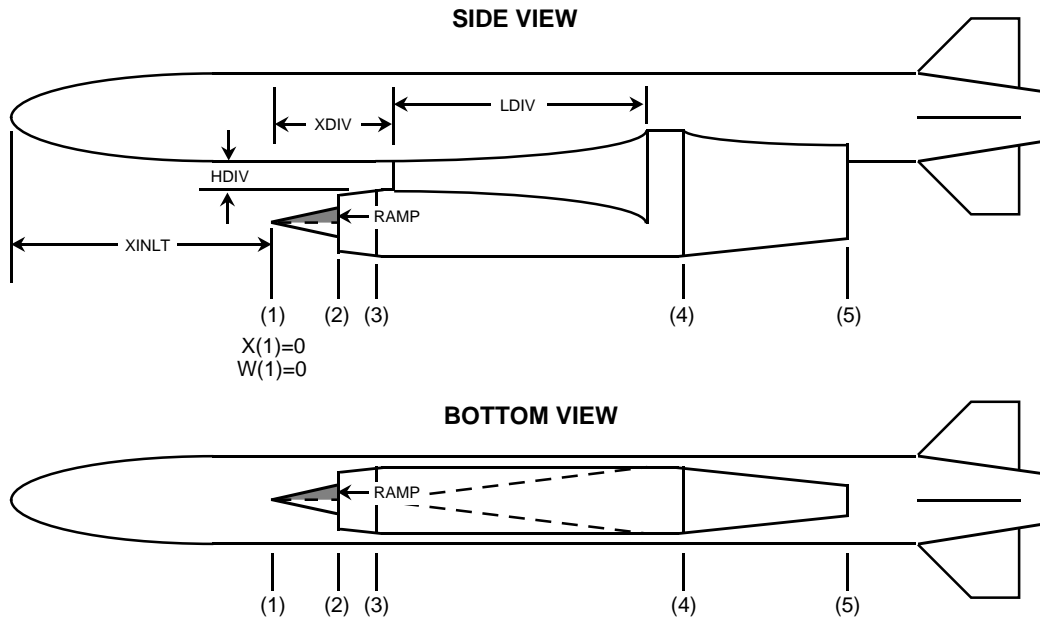

(2 INLETS ROTATED AT 120° AND 250°)

FRONT VIEW

INPUT INLET LONGITUDINAL COORDINATE (X), AND DIAMETER (W) AT EACH STATION

STATION	INLET POSITION
(1)	TIP ($X(1) & W(1) = 0$)
(2)	COWL LIP LEADING EDGE
(3)	MIDBODY START
(4)	BOATTAIL START
(5)	BOATTAIL END

INLET ALONE

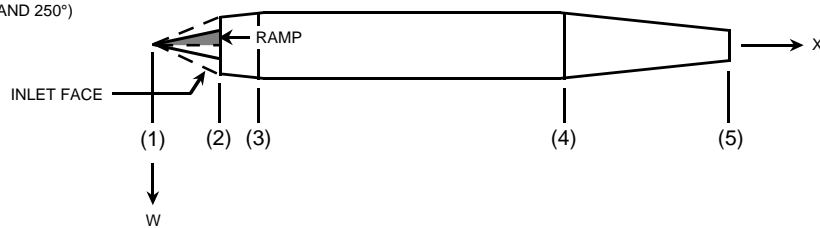

NOTES;

- INLET ROLL ORIENTATION IS SAME CONVENTION AS FIN ROLL ORIENTATION.
- RAMP IS THE EXTERNAL COMPRESSION CONE HALF-ANGLE (SHOWN SHADED IN THE SIDE VIEW)
- HEIGHT OF THE DIVERTER IS SPECIFIED AT THE DIVERTER LEADING EDGE
- THE DIVERTER WIDTH IS EQUAL TO THE INLET DIAMETER AT LDIV
- IF INLET IS COVERED (COVER=.TRUE.) A PLUG IS PLACED BETWEEN STATIONS 1 AND 2 FLUSH WITH THE INLET FACE

Figure 14 Axisymmetric Inlet/Diverter Geometry

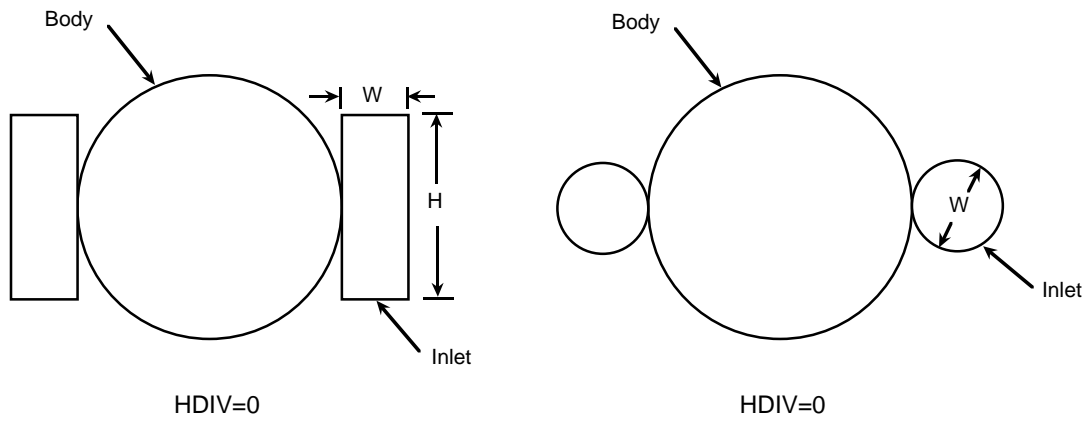

Conformal Inlets

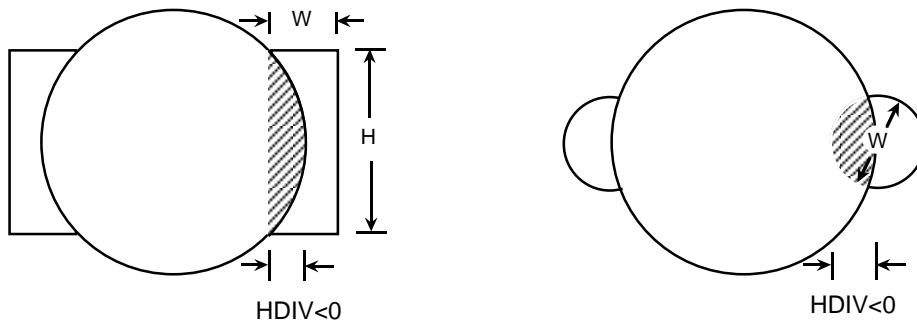

Semi-Submerged Inlets

Figure 15 Geometry Definition For Conformal And Semi-Submerged Inlets

NAMELIST EXPR

VARIABLE NAME	ARRAY SIZE	DEFINITION	UNITS	DEFAULT
MACH	-	Mach number	-	-
NALPHA	-	Number of angles of attack	-	-
ALPHA	20	Angles of attack for data	deg	-
SREF	-	Reference area for data	L*L	*
LREF	-	Longitudinal reference length For data	L	**
LATREF	-	Lateral reference length for data	L	LREF
XCG	-	Longitudinal C.G. for data	L	0.
ZCG	-	Vertical C.G. for data	L	0.
CONF	-	Configuration for which data is To be supplied: BODY (body) F1 (fin set 1) F2 (fin set 2) F3 (fin set 3) F4 (fin set 4) BF1 (body +1 fin set) BF12 (body +2 fin sets) BF123 (body +3 fin sets) BF1234 (body +4 fin sets)	-	-
CN	20	C_N data vs alpha	-	-
CM	20	C_m data vs alpha	-	-
CA	20	C_A data vs alpha	-	-
CY	20	C_Y data vs alpha	-	-
CSN	20	C_n data vs alpha	-	-
CSL	20	C_l data vs alpha	-	-

* Default is maximum body cross-sectional area. If no body is input, default is maximum fin panel area.

** Default is maximum body diameter. If no body is input, default is fin panel mean geometric chord.

Table 17 Experimental Data Inputs

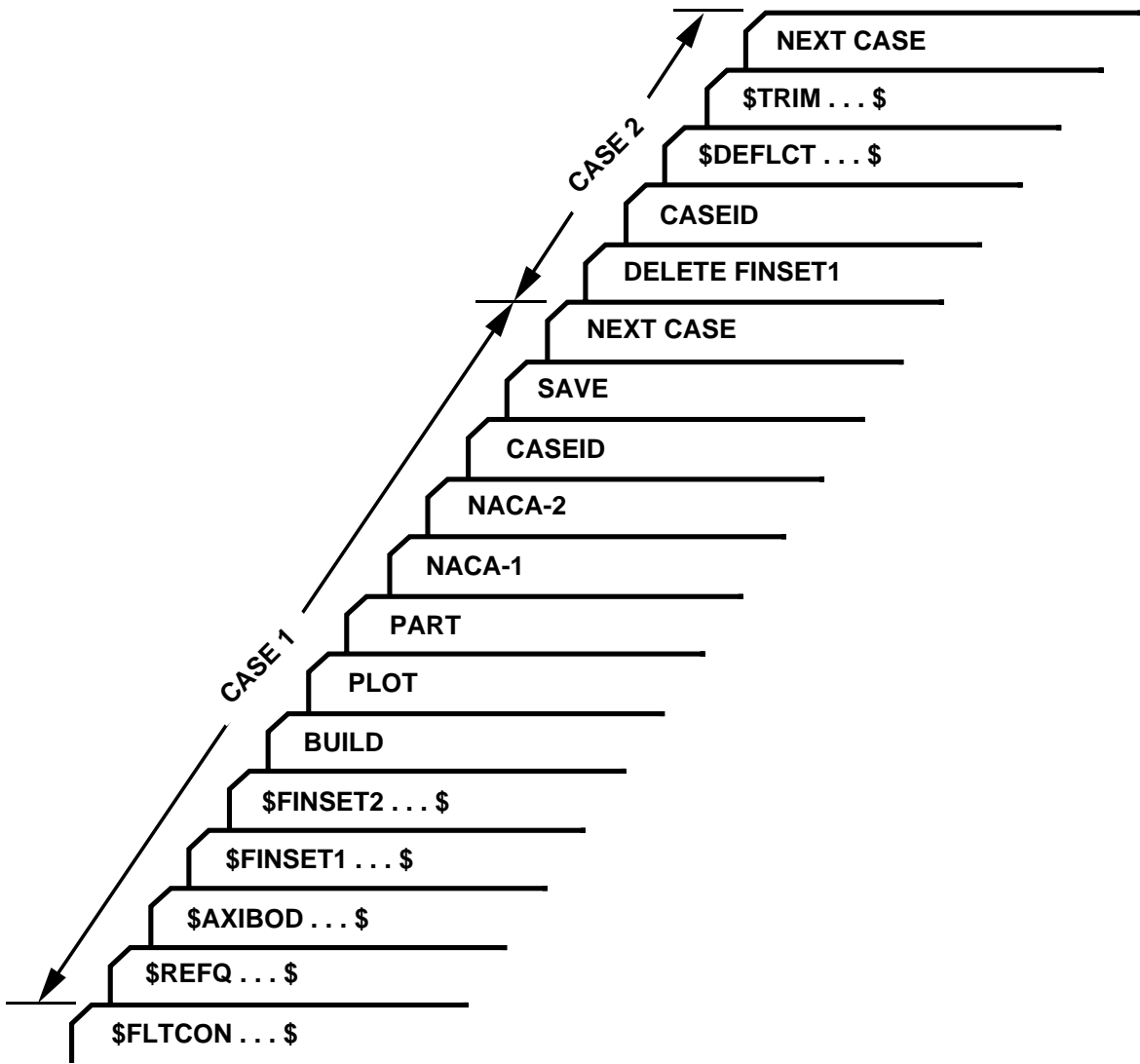

Figure 16 Typical "Stacked" Case Set-up

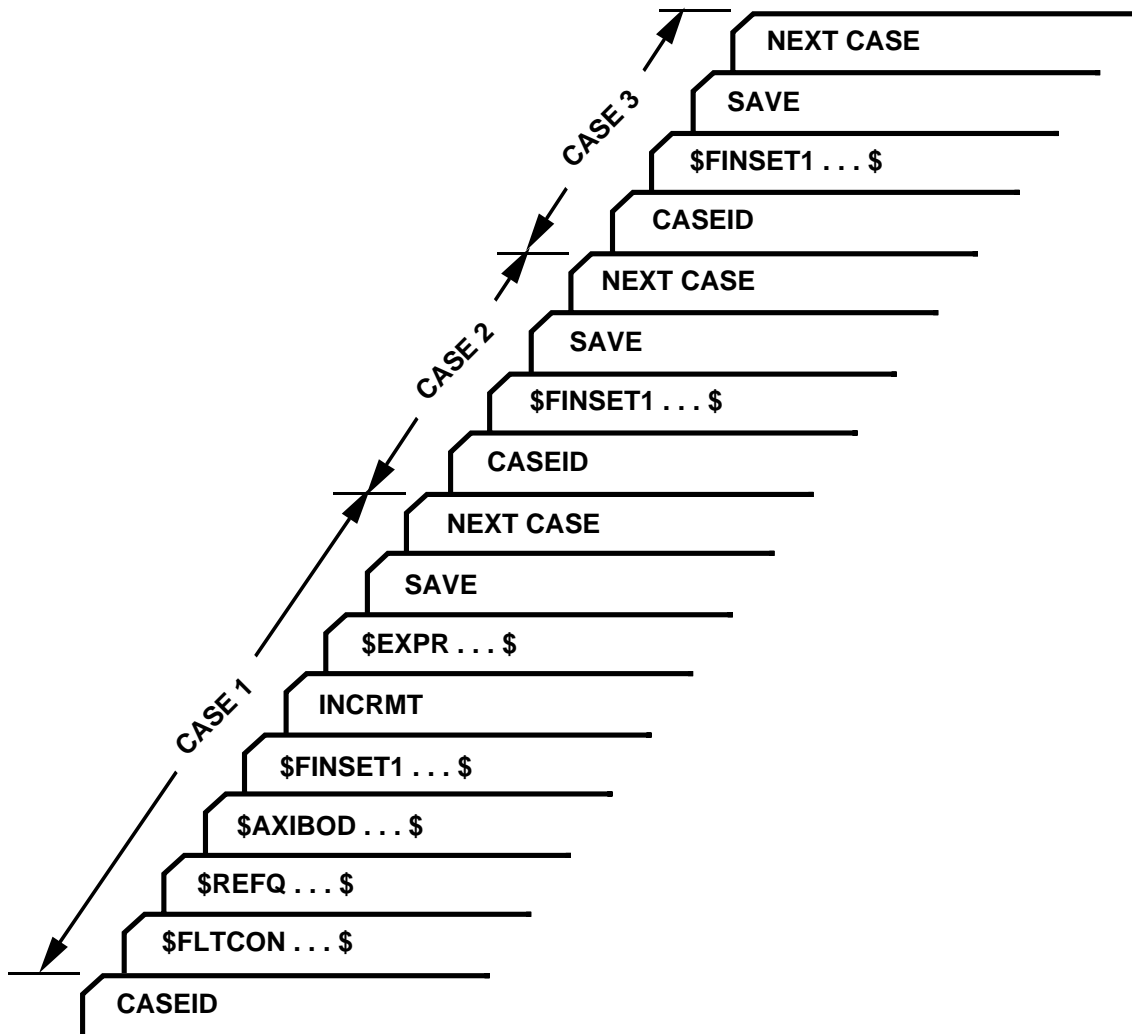

Figure 17 "Configuration Incrementing" Case Set-up

4.0 OUTPUT DESCRIPTION

This section describes the types of output available from the code. In many cases the available output is user selectable, that is, it is not normally provided and must be specifically requested using a specialized control card. This feature permits the user to tailor the code output to fit his particular application without extensive reprogramming. This allows him to find the output that he is interested in without having to wade through output that does not interest him.

The following four types of output are available from the code:

- Nominal output - This output is always provided by the code and consists of output from the input error checking module (CONERR), a listing of the inputs for each case, and the final aerodynamic results for the configuration.
- Partial output - This output details the configuration geometry and the intermediate aerodynamic calculations. Special control cards are available so that the user can select the quantity and types of output desired.
- External data files - This output permits the user to create external data files which can be used in post-processing programs, such as plotting or trajectory programs. Both fixed and user defined format data files can be created with the addition of simple control cards.
- Array dumps - This output permits the user to print internal data arrays (DUMP).

The remainder of the section describes each of these output data. Examples of each output page are also included and were created from the example problems, described in Appendix A, which can be used as a model for setting up another, similar configuration or be used as a means to check the proper operation of the code.

4.1 NOMINAL OUTPUT

Without the use of any program options the code will provide three types of output. First, an analysis by the input error checking routine is provided. It lists all input cards provided by the user and identifies any input errors detected. Second, a listing of all input cards, grouped by case, are provided; included in this output is an error analysis from the major input error routine MAJERR. Finally, the total configuration aerodynamics are provided in summary form; one page of aerodynamic output is supplied for each Mach number specified. The MAJERR results and the total configuration aerodynamics results are listed in succession for each case.

4.1.1 Input Error Checking

The purpose of the input error checking module is to provide single pass error checking of all inputs. If an error is detected, it is identified and an appropriate error message provided. The error messages are designed to be self-explanatory. In some cases, errors are automatically corrected by the routine, although the routine was not designed to be a comprehensive error correction utility.

The following errors are automatically corrected by the code:

- No terminating comma on a namelist input card
- No terminating "\$" or "\$END" on a namelist input ("&" on IBM systems)
- No terminating NEXT CASE for the case inputs for single case or last case inputs.

Errors detected by the error checking routine are considered either "FATAL" or "NON-FATAL". A "FATAL" error is one which will cause the code to terminate execution abnormally; examples of "FATAL" errors include incorrect spelling of any namelist name, incorrect spelling of any variable name, and any drastic input error in a namelist input, such as leaving out an equals sign in a constant definition. All "FATAL" errors are clearly identified on the output. A "NON-FATAL" error is one which will not cause the program to terminate execution; an example of a "NON-FATAL" error is leaving off the decimal point on numeric constants. All Missile Datcom inputs are either REAL or LOGICAL regardless of the variable name assigned. "NON-FATAL" errors will not cause the code to stop execution, whereas, "FATAL" errors will cause the code to stop execution after input error checking has been completed.

An example output from CONERR is shown in Figure 18. This figure illustrates the array of input errors checked by CONERR. Several additional features of the output are as follows:

- All user defined input cards are assigned a sequential "line number". This serves to identify user inputs from the code generated inputs (all code-created input cards are not identified with a "line number"). This scheme also permits the user to quickly identify those input cards in error so that efficient correction of input errors can be performed.
- All input cards are listed as input by the user. To the right of each input card is a listing of any errors encountered in processing that card. If no such error message appears then the input was interpreted as being correct.
- In many cases alphanumeric constants are available (see Table 3). Hence the user does not need to memorize a numeric scheme of "flags". Since some computers do not recognize alphanumeric constants as namelist constants, they are automatically converted by the code to their numeric equivalent. A message is printed to identify the substitutions performed.

In order to permit column independent inputs the code will automatically adjust some of the input cards to begin in columns 1 or 2. All control cards will be automatically shifted to start in column 1; all namelists which begin in column 1 will be shifted to column 2. If any input card cannot be shifted to conform to this scheme, an error message will be produced. As a general rule, column 80 of namelist inputs should be left blank so that the code can shift the card image, if necessary.

4.1.2 Listing of Case Input Data

Figure 19 shows the first page of outputs for a case without CONERR detected errors. Then Figure 20 shows the next page of output which lists all input cards for the case (down to the NEXT CASE control card). If the input for a case is from a previous case (through use of the SAVE control card) only the new case inputs are listed. All saved inputs are not repeated in subsequent case input summaries.

After the case data have been read, the data set-up for the case is analyzed by the case major error checking module (MAJERR). The purpose of this second error checking is to insure that the data input, although syntax error free, properly defines a case to be run. Examples of errors detected in MAJERR include valid flight condition inputs, valid reference condition inputs, and that geometry has been defined. In most cases errors detected by MAJERR are corrected with assumed defaults. If any MAJERR error message is produced, the user should verify the "fix-up" taken by the code. In some cases a "fix-up" is not possible; an appropriate error message and a suggestion for correcting the error is provided. If a "fix-up" is not possible the case will not run.

4.1.3 Case Total Configuration Aerodynamic Output Summary

As shown in Figure 21, the total configuration aerodynamics are provided in compact form for easy review. The aerodynamics are summarized as a function of angle of attack (ALPHA) in the user specified system of units, and are given in the body axis system (except for lift and drag, which are given in stability axes). The nomenclature is as follows:

CN	- Normal force coefficient
CM	- Pitching moment coefficient
CA	- Axial force coefficient
CY	- Side force coefficient
CLN	- Yawing moment coefficient
CLL	- Rolling moment coefficient
CNA	- Normal force coefficient derivative with ALPHA
CMA	- Pitching moment coefficient derivative with ALPHA
CYB	- Side force coefficient derivative with BETA
CLNB	- Yawing moment coefficient derivative with BETA
CLLB	- Rolling moment coefficient derivative with BETA
CL	- Lift coefficient
CD	- Drag coefficient
CL/CD	- Lift to drag ratio
XCP	- Center of pressure position, measures x from the moment reference center, divided by reference length. Positive values indicate c.p. forward of the moment reference point.

All coefficients are based upon the reference areas and lengths specified at the top of the output page. The derivatives CNA and CMA are computed by numeric differentiation of the CN and CM curves, respectively; precise derivatives are only obtained when the angle of attack range specified is narrow. The derivatives CYB, CLNB, and CLLB are determined by perturbing the sideslip angle by one degree, recalculating the configuration forces and moments, and then differencing with the user specified orientation. Hence, the longitudinal and lateral derivatives may not be numerically identical for those conditions which should produce identical results if they were both calculated by the same method.

A significant decrease in computational time is realized when the calculation of lateral-directional derivatives are suppressed using the control card NO LAT. For these cases, the CYB, CLNB, and CLLB data fields are filled with blanks.

When selecting TRIM, the output is provided in a form similar to Figure 22. When running a trim case the derivatives due to ALPHA and BETA are not available. The panels which were deflected to trim the configuration are indicated by the "VARIED" citation next to them.

The format for the values of the numbers in the printed output has been assumed based on typical magnitudes for missile aerodynamic coefficients. In some cases, a user specified reference area and/or length will cause the results to underflow or overflow the format selected. For these cases the user should adjust his reference quantities by powers of ten to get the data to fit the format specified.

4.2 PARTIAL OUTPUT

Partial output consists of geometry calculation details, intermediate aerodynamic results, or auxiliary data, such as pressure distributions. Each of these output types are printed through the addition of control cards input for each case. In all cases, partial output requested for one case is not automatically selected for subsequent cases, and the control cards must be re-input. This permits the user to be selective on the amount and types of output desired.

A special control card PART permits the user to request all geometric and aerodynamic partial output. Due to the amount of output produced, this option should be used sparingly or when details of the calculations are desired.

The following paragraphs describe the output received when partial output is requested.

4.2.1 Geometric Partial Output

Details of the geometry are provided when the PART or PRINT GEOM control cards are included in the case inputs. Figure 23 shows the output created when the PRINT GEOM BODY control card is used. Detailed are the results of the geometric calculations for the body. Included are such items as planform area, surface (wetted) area, and the mold line contour.

If fins are present on the configuration, two types of fin geometry data are produced when PRINT GEOM FIN1 or PART is requested. As shown in Figure 24, the description of the panel airfoil section is provided. Following that, shown in Figure 25, is a summary of the major geometric characteristics of such planform; note that fin planform geometry data is given for one panel of each fin set, since it is assumed that each fin of a fin set is identical. If a panel is made up of multiple segments, the geometric data is provided by panel segment (each segment is assigned a number starting at the root). Total panel set of characteristics is also provided. This total panel data represents an equivalent straight-tapered panel, which is used for most of the aerodynamic calculations. The thickness-to-chord ratio shown for each segment is that value at the segment root; for the total panel, it is an "effective" value.

If an airbreathing inlet is specified the output is similar to that in Figure 26. This output reflects the user input definition for the inlet design specified. It is provided if the PRINT GEOM INLET or PART control cards are included in the input case.

4.2.2 Aerodynamic Partial Output

The output on the configuration aerodynamics is most extensive when PRINT AERO or PART is specified. Output is created for the body and each fin set on the configuration. In addition, for any

subsonic/transonic Mach number (less than 1.4) an analysis by the Airfoil Section Module is made, which involves a potential flow analysis of the airfoil section using conformal mapping. If a configuration has inlets additional partial output is included to summarize the inlet external aerodynamics.

If base-jet plume interaction calculations are specified (BASE=.TRUE. in namelist AXIBOD), then there will be one or two separate pages of output. Figure 27 shows an example of the first page of output. This page will always be printed if BASE=.TRUE. The base pressure coefficient, axial force coefficient, and freestream pressure and temperature ratios are shown versus angle of attack. Also, the incremental forces and moments due to separation are shown versus angle of attack. If extrapolation of the base pressures and separation conditions database occurs, a warning message is printed explaining what input variable required extrapolation. A second page of output containing the boattail separation parameters will be printed if there are any fins on the missile boattail. The separation location aft of the nose and the Mach cone angle are shown versus angle of attack for each panel on the fin set. This output is provided if the PRINT AERO BODY or PART control card is input.

The protuberance partial output is printed if PRINT AERO BODY or PART is used. This output will only be shown if the namelist PROTUB is present in the input file. Figure 28 is an example of the protuberance output. Protuberance type, location, number, and axial force coefficient are listed for each protuberance set. The total axial force coefficient or zero lift drag coefficient is printed at the bottom of the page.

As shown in Figure 29, the body alone partial aerodynamic output for normal force lists the axial force contributors, potential normal force (CN-POTENTIAL), viscous normal forces (CN-VISCOUS), potential pitching moment (CM-POTENTIAL), viscous pitching moment (CM-VISCOUS), and the crossflow drag coefficient (CDC). The cross-flow drag proportionality factor at subsonic and transonic speeds is also given for reference. These data are similar to that obtained for elliptical bodies.

Figure 30 details the fin normal force and pitching moment calculations by fin set. The columns titled POTENTIAL are the potential flow contribution and the columns titled VISCOUS are the viscous flow contribution. Their sum is given in the columns titled TOTAL. Figure 31 illustrates the contributions to fin axial force.

The analysis by the Airfoil Section Module is provided in a format similar to Figure 32. If any Mach number specified produces supersonic flow on the airfoil surface, the message "CREST CRITICAL MACH NUMBER EXCEEDED" will be printed; approximation of the airfoil section data is then assumed. These fin aerodynamic increments are repeated for each fin set on the configuration. Note that the Airfoil Section Module assumes that the panels have sharp trailing edges. Any panel input with a non-sharp trailing edge will have its aerodynamic characteristics set as though the airfoil was "ideal". This assumption is approximate for preliminary design.

Figure 33 shows the aerodynamic output available when inlets are specified on the configuration. It is provided when PRINT AERO INLET or PART is specified in the case inputs. The aerodynamics summarized for inlets can include additive drag results if the user input the additive drag calculation flag. The maximum mass flow ratio is printed at the bottom of the page if the additive drag is calculated. If additive drag cannot be calculated, a warning message is printed.

After the aerodynamic details for each component of the configuration are output, the aerodynamic calculations for the synthesis of the complete configuration follows. For the example case, fin set 1 results would be followed by fin set 2 results for each of the following outputs:

- "FIN SET IN PRESENCE OF THE BODY" - This summarizes the aerodynamic incrementals of the most forward set of fins with the influence of the body. Figures 34-35 presents the example of this output. Figure 34 shows the total effect of body-on-fin component interference. Figure 35 shows how the individual panels contribute to the total normal force. AEQ_n is the panel equivalent angle of attack, and CN_n is the panel normal force. The sign convention is as follows: a positive panel normal force, hence, equivalent angle of attack, produces a negative roll moment. Therefore, panels on the right side of the configuration will produce loads and angles of attack opposite in sign to those on the left side of the configuration even though they produce the same physical force loading.
- "BODY-FIN SET" - Aerodynamics for the body plus most forward set of fins configuration. It is produced through addition of the body alone and wing in presence of the body incrementals, described above. The results include the component carryover factors $K-W(B)$ (wing in presence of the body carryover due to angle of attack), $K-B(W)$ (body in presence of the wing carryover due to angle of attack), $KK-B(W)$ (body in presence of the wing carryover due to panel deflection), $XCP-W(B)$ (wing in presence of the body carryover center of pressure), and $XCP-B(W)$ (body in presence of the wing carryover center of pressure). This output is repeated for the body plus each additional aft fin set, if one exists on the configuration.
- "CARRYOVER INTERFERENCE FACTORS" - This page of partial output summarizes the carryover factors listed in the paragraph above. These were included in the body plus fin set calculations. An example of this output is presented in Figure 36.
- "COMPLETE CONFIGURATION" - Complete configuration aerodynamics. This output was illustrated in Figure 21. The values are obtained by summing the body-wing and tail in the presence of the wing flow field data.

In addition to the output described above, more data is presented when the BUILD control card is used. Static aerodynamics are output for each configuration component.

If the PRINT AERO BEND or PART control card is used, the code will compute and print panel bending moment coefficients for each fin set on a separate page. One page is shown in Figure 37. The sign convention is that assumed for the individual panel loads and equivalent angles of attack, noted above. The bending moment coefficients are based upon the reference area and longitudinal length given at the top of the page. The moments are referenced about the fin-body structure specified by the root chord span station.

Figure 38 illustrates the panel hinge moments coefficients computed when the control cards PRINT AERO HINGE or PART are used. The reference area and longitudinal reference length given at the top of the page are used. All moments are computed about the hinge line, which is defined using namelist DEFLCT.

4.2.3 Dynamic Derivatives

As shown in Figure 39, the total configuration dynamic derivatives are provided in compact form for easy interpretation. The dynamic derivatives are summarized as a function of angle of attack in the user specified units. All derivatives are in the body axis system, with assumed rates of rotation also in that system. The coefficients provided are as follows:

CNQ	Normal force coefficient due to pitch rate
CMQ	Pitching moment coefficient due to pitch rate
CAQ	Axial force coefficient due to pitch rate
CNAD	Normal force coefficient due to rate of change of angle of attack
CMAD	Pitching moment coefficient due to rate of change of angle of attack
CYR	Side force coefficient due to yaw rate
CLNR	Yawing moment coefficient due to yaw rate
CLLR	Rolling moment coefficient due to yaw rate
CYP	Side force coefficient due to roll rate
CLNP	Yawing moment coefficient due to roll rate
CLLP	Rolling moment coefficient due to roll rate

The dynamic derivatives are printed after all static coefficients and partial static aerodynamics are printed. If a BUILD or PART card is input, additional dynamic derivatives for partial configurations and/or configuration components are printed. All six force and moment components due to each of the three body axis rotation rates are available in arrays which can be written to file "for004.dat" using the WRITE command. The locations of the appropriate array elements are shown in Table 22.

```

1          ***** THE USAF AUTOMATED MISSILE DATCOM * REV 5/97 *****
              AERODYNAMIC METHODS FOR MISSILE CONFIGURATIONS

CONERR - INPUT ERROR CHECKING

ERROR CODES - N* DENOTES THE NUMBER OF OCCURENCES OF EACH ERROR
A - UNKNOWN VARIABLE NAME
B - MISSING EQUAL SIGN FOLLOWING VARIABLE NAME
C - NON-ARRAY VARIABLE HAS AN ARRAY ELEMENTDESIGNATION - (N)
D - NON-ARRAY VARIABLE HAS MULTIPLE VALUES ASSIGNED
E - ASSIGNED VALUES EXCEED ARRAY DIMENSION
F - SYNTAX ERROR

***** INPUT DATA CARDS *****

1 *
2 * INPUT ERROR CHECK CASE
3 *
4 $FLTCON NMCACHE=2.,$
   ** ERROR ** 1*A 0*B 0*C 0*D 0*E 0*F
   * FATAL ERROR *
5 $REFQ SREF 100.,$
   ** ERROR ** 0*A 1*B 0*C 0*D 0*E 0*F
   * FATAL ERROR *
6 $AXIBOD DNOSE(2)=5.0,$
   ** ERROR ** 0*A 0*B 1*C 0*D 0*E 0*F
   * FATAL ERROR *
7 $FINSET1 NPANEL=2.,3.,4.,$
   ** ERROR ** 0*A 0*B 0*C 1*D 0*E 0*F
   * FATAL ERROR *
8 $FINSET2 PHIF(10)=33.0,$
   ** ERROR ** 0*A 0*B 0*C 0*D 1*E 0*F
   * FATAL ERROR *
9 $INLET NIN=1,$
   ** ERROR ** 0*A 0*B 0*C 0*D 0*E 1*F
10 BUILT
   ** ERROR ** UNKNOWN CONTROL CARD - IGNORED
11 $AXIBD LNOSE=5.,DNOSE=1.,LCENTR=1.,$
   ** ERROR ** UNKNOWN NAMELIST NAME
NEXT CASE ** MISSING NEXT CASE CARD ADDED **
FATAL ERROR ENCOUNTERED IN CONERR. PROGRAM STOPPED

```

Figure 18 Input Error Checking Output

```

ERROR CODES - N* DENOTES THE NUMBER OF OCCURENCES OF EACH ERROR
A - UNKNOWN VARIABLE NAME
B - MISSING EQUAL SIGN FOLLOWING VARIABLE NAME
C - NON-ARRAY VARIABLE HAS AN ARRAY ELEMENT DESIGNATION - (N)
D - NON-ARRAY VARIABLE HAS MULTIPLE VALUES ASSIGNED
E - ASSIGNED VALUES EXCEED ARRAY DIMENSION
F - SYNTAX ERROR

***** INPUT DATA CARDS *****

1 $FLTCON NALPHA=8.,NMACH=1.,MACH=2.36,REN=3000000.,
2     ALPHA=0.,4.,8.,12.,
3     ALPHA(5)=16.,20.,24.,28.,$
4 $REFQ XCG=18.75,$
5 $AXIBOD LNOSE=11.25,DNOSE=3.75,LCENTR=26.25,DEXIT=0.,$
6 $FINSET1 XLE=15.42,NPANEL=2.,PHIF=90.,270.,SWEEP=0.,STA=1.,
7     CHORD=6.96,0.,SSPAN=1.875,5.355,
8     ZUPPER=2*0.02238,LMAXU=0.238,0.238,
9     LFLATU=0.524,0.524,LER=2*0.015,$
10 $FINSET2 XLE=31.915,NPANEL=4.,PHIF=0.,90.,180.,270.,LER=2*0.015,
11     SWEEP=0.,STA=1.,SSPAN=1.875,6.26,CHORD=5.585,2.792,
12     ZUPPER=2*0.02238,LMAXU=2*0.288,LFLATU=2*0.428,$
13 PART
14 PLOT
15 DAMP
16 SOSE
17 SAVE
18 DIM IN
19 CASEID PLANAR WING, CRUCIFORM PLUS TAIL CONFIGURATION
20 NEXT CASE
21 CASEID TRIM OF CASE NUMBER 1
22 $TRIM SET=2.,$
23 PRINT AERO TRIM
24 NEXT CASE

```

Figure 19 Case Input Listing

```

1          ***** THE USAF AUTOMATED MISSILE DATCOM * REV 5/97 *****          CASE 1
          AERODYNAMIC METHODS FOR MISSILE CONFIGURATIONS                          PAGE 1
CASE INPUTS
FOLLOWING ARE THE CARDS INPUT FOR THIS CASE

$FLTCON NALPHA=8.,NMACH=1.,MACH=2.36,REN=3000000.,
        ALPHA=0.,4.,8.,12.,
        ALPHA(5)=16.,20.,24.,28.,$
$REFQ XCG=18.75,$
$AXIBOD LNOSE=11.25,DNOSE=3.75,LCENTR=26.25,DEXIT=0.,$
$FINSET1 XLE=15.42,NPANEL=2.,PHIF=90.,270.,SWEEP=0.,STA=1.,
        CHORD=6.96,0.,SSPAN=1.875,5.355,
        ZUPPER=2*0.02238,LMAXU=0.238,0.238,
        LFLATU=0.524,0.524,LER=2*0.015,$
$FINSET2 XLE=31.915,NPANEL=4.,PHIF=0.,90.,180.,270.,LER=2*0.015,
        SWEEP=0.,STA=1.,SSPAN=1.875,6.26,CHORD=5.585,2.792,
        ZUPPER=2*0.02238,LMAXU=2*0.288,LFLATU=2*0.428,$

PART
PLOT
DAMP
SOSE
SAVE
DIM IN
CASEID PLANAR WING, CRUCIFORM PLUS TAIL CONFIGURATION
NEXT CASE
* WARNING * THE REFERENCE AREA IS UNSPECIFIED, DEFAULT VALUE ASSUMED
* WARNING * THE REFERENCE LENGTH IS UNSPECIFIED, DEFAULT VALUE ASSUMED
* WARNING * CENTER SECTION DEFINED BUT BASE DIAMETER NOT INPUT
          CYLINDRICAL SECTION ASSUMED
THE BOUNDARY LAYER IS ASSUMED TO BE TURBULENT
THE INPUT UNITS ARE IN INCHES, THE SCALE FACTOR IS 1.0000

```

Figure 20 Example of Default Substitutions for Incomplete Case Inputs

1 ***** THE USAF AUTOMATED MISSILE DATCOM * REV 5/97 ***** CASE 1
 AERODYNAMIC METHODS FOR MISSILE CONFIGURATIONS PAGE 21
 PLANAR WING, CRUCIFORM PLUS TAIL CONFIGURATION
 STATIC AERODYNAMICS FOR BODY-FIN SET 1 AND 2

***** FLIGHT CONDITIONS AND REFERENCE QUANTITIES *****
 MACH NO = 2.36 REYNOLDS NO = 3.000E+06 /FT
 SIDESLIP = 0.00 DEG ROLL = 0.00 DEG
 REF AREA = 11.045 IN**2 MOMENT CENTER = 18.750 IN
 REF LENGTH = 3.75 IN LAT REF LENGTH = 3.75 IN

ALPHA	----- LONGITUDINAL -----			-- LATERAL DIRECTIONAL --		
	CN	CM	CA	CY	CLN	CLL
0.00	0.000	0.000	0.466	0.000	0.000	0.000
4.00	1.179	-1.577	0.465	0.000	0.000	0.000
8.00	2.476	-3.194	0.463	0.000	0.000	0.000
12.00	3.992	-5.056	0.458	0.000	0.000	0.000
16.00	5.582	-6.962	0.453	0.000	0.000	0.000
20.00	7.151	-8.904	0.445	0.000	0.000	0.000
24.00	8.601	-10.792	0.436	0.000	0.000	0.000
28.00	10.093	-12.692	0.426	0.000	0.000	0.000
ALPHA	CL	CD	CL/CD	X-C.P.		
0.00	0.000	0.466	0.000	-1.389		
4.00	1.144	0.546	2.093	-1.337		
8.00	2.387	0.803	2.974	-1.290		
12.00	3.810	1.279	2.980	-1.266		
16.00	5.241	1.974	2.655	-1.247		
20.00	6.568	2.864	2.293	-1.245		
24.00	7.680	3.897	1.971	-1.255		
28.00	8.711	5.114	1.703	-1.258		

X-C.P. MEAS. FROM MOMENT CENTER IN REF. LENGTHS, NEG. AFT OF MOMENT CENTER
 1 ***** THE USAF AUTOMATED MISSILE DATCOM * REV 5/97 ***** CASE 1
 AERODYNAMIC METHODS FOR MISSILE CONFIGURATIONS PAGE 22
 PLANAR WING, CRUCIFORM PLUS TAIL CONFIGURATION
 STATIC AERODYNAMICS FOR BODY-FIN SET 1 AND 2

***** FLIGHT CONDITIONS AND REFERENCE QUANTITIES *****
 MACH NO = 2.36 REYNOLDS NO = 3.000E+06 /FT
 SIDESLIP = 0.00 DEG ROLL = 0.00 DEG
 REF AREA = 11.045 IN**2 MOMENT CENTER = 18.750 IN
 REF LENGTH = 3.75 IN LAT REF LENGTH = 3.75 IN

ALPHA	----- DERIVATIVES (PER DEGREE) -----				
	CNA	CMA	CYB	CLNB	CLLB
0.00	0.2802	-0.3892	-0.1993	0.4893	0.0000
4.00	0.3094	-0.3992	-0.2082	0.4797	-0.0105
8.00	0.3514	-0.4345	-0.2150	0.4493	-0.0187
12.00	0.3882	-0.4711	-0.2151	0.3594	-0.0110
16.00	0.3949	-0.4810	-0.2037	0.2255	0.0080
20.00	0.3774	-0.4787	-0.1896	0.1163	0.0320
24.00	0.3676	-0.4735	-0.1740	0.0449	0.0486
28.00	0.3780	-0.4766	-0.1642	-0.0028	0.0615

PANEL DEFLECTION ANGLES (DEGREES)

SET	FIN 1	FIN 2	FIN 3	FIN 4	FIN 5	FIN 6	FIN 7	FIN 8
1	0.00	0.00						
2	0.00	0.00	0.00	0.00				

BODY ALONE LINEAR DATA GENERATED FROM SECOND ORDER SHOCK EXPANSION METHOD

Figure 21 Total Configuration Aerodynamic Output Summary

1

***** THE USAF AUTOMATED MISSILE DATCOM * REV 5/97 *****
AERODYNAMIC METHODS FOR MISSILE CONFIGURATIONS
TRIM OF CASE NUMBER 1
STATIC AERODYNAMIC COEFFICIENTS TRIMMED IN PITCH

CASE 2
PAGE 2

***** FLIGHT CONDITIONS AND REFERENCE QUANTITIES *****
MACH NO = 2.36 REYNOLDS NO = 3.000E+06 /FT
SIDESLIP = 0.00 DEG ROLL = 0.00 DEG
REF AREA = 11.045 IN**2 MOMENT CENTER = 18.750 IN
REF LENGTH = 3.75 IN LAT REF LENGTH = 3.75 IN

ALPHA	DELTA	CL	CD	CN	CA
0.00	0.00	0.000	0.466	0.000	0.466
4.00	-3.77	0.786	0.524	0.821	0.468
8.00	-7.49	1.669	0.697	1.750	0.457
12.00	-11.50	2.690	1.021	2.843	0.439
16.00	-15.23	3.730	1.503	4.000	0.416
20.00	-19.15	4.681	2.134	5.128	0.404
24.00	-23.17	5.458	2.860	6.150	0.393
28.00	*NT*	*NT*	*NT*	*NT*	*NT*

PANELS FROM FIN SET 2 WERE DEFLECTED OVER THE RANGE -25.00 TO 20.00 DEG
PANEL 1 WAS FIXED
PANEL 2 WAS VARIED
PANEL 3 WAS FIXED
PANEL 4 WAS VARIED
NOTE - *NT* PRINTED WHEN NO TRIM POINT COULD BE FOUND
*** END OF JOB ***

Figure 22 Trimmed Output Summary

1

***** THE USAF AUTOMATED MISSILE DATCOM * REV 5/97 *****
 AERODYNAMIC METHODS FOR MISSILE CONFIGURATIONS
 PLANAR WING, CRUCIFORM PLUS TAIL CONFIGURATION
 AXISYMMETRIC BODY DEFINITION

CASE 1
 PAGE 2

SHAPE	NOSE	CENTERBODY	AFT BODY	TOTAL	
	OGIVE	CYLINDER	-----		
LENGTH	11.250	26.250	0.000	37.500	IN
FINENESS RATIO	3.000	7.000	0.000	10.000	
PLANFORM AREA	28.280	98.437	0.000	126.717	IN**2
AREA CENTROID	7.016	24.375	0.000	20.501	IN
WETTED AREA	89.818	309.251	0.000	399.069	IN**2
VOLUME	66.789	289.922	0.000	356.711	IN**3
VOL. CENTROID	7.714	24.375	0.000	21.255	IN

MOLD LINE CONTOUR

LONGITUDINAL STATIONS	0.0000	1.1250	2.2500	3.3750	4.5000
5.6250	6.7500	7.8750	9.0000	10.1250	11.2500
16.5000	19.1250	21.7500	24.3750	27.0000	29.6250
34.8750	37.5000*				32.2500

BODY RADII	0.0000	0.3644	0.6871	0.9693	1.2119
1.4159	1.5819	1.7104	1.8020	1.8568	1.8750
1.8750	1.8750	1.8750	1.8750	1.8750	1.8750
1.8750	1.8750*				

NOTE - * INDICATES SLOPE DISCONTINUOUS POINTS

Figure 23 Body Geometry Output

NACA S-3-23.8-04.5-52.4

X/C	X-UPPER	Y-UPPER	X-LOWER	Y-LOWER	MEAN LINE	THICKNESS
0.00000	0.00000	0.00000	0.00000	0.00000	0.00000	0.00000
0.00100	0.00100	0.00009	0.00100	-0.00009	0.00000	0.00019
0.00200	0.00200	0.00019	0.00200	-0.00019	0.00000	0.00038
0.00300	0.00300	0.00028	0.00300	-0.00028	0.00000	0.00057
0.00400	0.00400	0.00038	0.00400	-0.00038	0.00000	0.00076
0.00500	0.00500	0.00047	0.00500	-0.00047	0.00000	0.00095
0.00600	0.00600	0.00057	0.00600	-0.00057	0.00000	0.00113
0.00800	0.00800	0.00076	0.00800	-0.00076	0.00000	0.00151
0.01000	0.01000	0.00095	0.01000	-0.00095	0.00000	0.00189
0.02000	0.02000	0.00189	0.02000	-0.00189	0.00000	0.00378
0.03000	0.03000	0.00284	0.03000	-0.00284	0.00000	0.00567
0.04000	0.04000	0.00378	0.04000	-0.00378	0.00000	0.00756
0.05000	0.05000	0.00473	0.05000	-0.00473	0.00000	0.00945
0.06000	0.06000	0.00567	0.06000	-0.00567	0.00000	0.01134
0.08000	0.08000	0.00756	0.08000	-0.00756	0.00000	0.01513
0.10000	0.10000	0.00945	0.10000	-0.00945	0.00000	0.01891
0.12000	0.12000	0.01134	0.12000	-0.01134	0.00000	0.02269
0.14000	0.14000	0.01324	0.14000	-0.01324	0.00000	0.02647
0.16000	0.16000	0.01513	0.16000	-0.01513	0.00000	0.03025
0.18000	0.18000	0.01702	0.18000	-0.01702	0.00000	0.03403
0.20000	0.20000	0.01891	0.20000	-0.01891	0.00000	0.03782
0.22000	0.22000	0.02080	0.22000	-0.02080	0.00000	0.04160
0.24000	0.24000	0.02250	0.24000	-0.02250	0.00000	0.04500
0.26000	0.26000	0.02250	0.26000	-0.02250	0.00000	0.04500
0.28000	0.28000	0.02250	0.28000	-0.02250	0.00000	0.04500
0.30000	0.30000	0.02250	0.30000	-0.02250	0.00000	0.04500
0.32000	0.32000	0.02250	0.32000	-0.02250	0.00000	0.04500
0.34000	0.34000	0.02250	0.34000	-0.02250	0.00000	0.04500
0.36000	0.36000	0.02250	0.36000	-0.02250	0.00000	0.04500
0.38000	0.38000	0.02250	0.38000	-0.02250	0.00000	0.04500
0.40000	0.40000	0.02250	0.40000	-0.02250	0.00000	0.04500
0.42000	0.42000	0.02250	0.42000	-0.02250	0.00000	0.04500
0.45000	0.45000	0.02250	0.45000	-0.02250	0.00000	0.04500
0.50000	0.50000	0.02250	0.50000	-0.02250	0.00000	0.04500
0.55000	0.55000	0.02250	0.55000	-0.02250	0.00000	0.04500
0.60000	0.60000	0.02250	0.60000	-0.02250	0.00000	0.04500
0.65000	0.65000	0.02250	0.65000	-0.02250	0.00000	0.04500
0.70000	0.70000	0.02250	0.70000	-0.02250	0.00000	0.04500
0.75000	0.75000	0.02250	0.75000	-0.02250	0.00000	0.04500
0.80000	0.80000	0.01891	0.80000	-0.01891	0.00000	0.03782
0.82000	0.82000	0.01702	0.82000	-0.01702	0.00000	0.03403
0.84000	0.84000	0.01513	0.84000	-0.01513	0.00000	0.03025
0.86000	0.86000	0.01324	0.86000	-0.01324	0.00000	0.02647
0.88000	0.88000	0.01134	0.88000	-0.01134	0.00000	0.02269
0.90000	0.90000	0.00945	0.90000	-0.00945	0.00000	0.01891
0.92000	0.92000	0.00756	0.92000	-0.00756	0.00000	0.01513
0.94000	0.94000	0.00567	0.94000	-0.00567	0.00000	0.01134
0.96000	0.96000	0.00378	0.96000	-0.00378	0.00000	0.00756
0.98000	0.98000	0.00189	0.98000	-0.00189	0.00000	0.00378
1.00000	1.00000	0.00000	1.00000	0.00000	0.00000	0.00000

Figure 24 Airfoil Geometry Output

1

***** THE USAF AUTOMATED MISSILE DATCOM * REV 5/97 *****
 AERODYNAMIC METHODS FOR MISSILE CONFIGURATIONS
 PLANAR WING, CRUCIFORM PLUS TAIL CONFIGURATION
 GEOMETRIC RESULTS FOR FIN SETS

CASE 1
 PAGE 5

FIN SET NUMBER 1
 (DATA FOR ONE PANEL ONLY)

SEGMENT NUMBER	PLAN AREA	ASPECT RATIO	TAPER RATIO	L.E. SWEEP	T.E. SWEEP	M.A.C. CHORD	T/C RATIO
1	12.1104	1.000	0.000	63.435	0.000	4.640	0.045
TOTAL	12.1104	1.000	0.000	63.435	0.000	4.640	0.045

FIN SET NUMBER 2
 (DATA FOR ONE PANEL ONLY)

SEGMENT NUMBER	PLAN AREA	ASPECT RATIO	TAPER RATIO	L.E. SWEEP	T.E. SWEEP	M.A.C. CHORD	T/C RATIO
1	18.3666	1.047	0.500	32.495	0.000	4.344	0.045
TOTAL	18.3666	1.047	0.500	32.495	0.000	4.344	0.045

Figure 25 Fin Geometry Output

1

***** THE USAF AUTOMATED MISSILE DATCOM * REV 5/97 *****
AERODYNAMIC METHODS FOR MISSILE CONFIGURATIONS
INLET GEOMETRY

CASE 1
PAGE 5

INLET IS A TOP MOUNTED TWO-DIMENSIONAL TYPE

THE INLETS ARE OPEN

EXTERNAL COMPRESSION RAMP ANGLE (DEG) = 0.00

NUMBER OF INLETS = 2

INLET ANGULAR ROLL POSITIONS FROM TOP VERTICAL CENTER (DEG)
(SAME CONVENTION AS FIN ROLL POSITIONS)
135.0 225.0

LONGITUDINAL DISTANCE FROM MISSILE NOSE TIP TO
INLET LEADING EDGE = 81.65

INLET POSITIONS RELATIVE TO THE LEADING EDGE			
POSITION	LONGITUDINAL	WIDTH	HEIGHT
TOP LIP LEADING EDGE	0.000	0.000	0.000
COWL LIP LEADING EDGE	9.435	2.100	2.100
MID BODY START	18.870	4.200	4.200
BOATTAIL START	58.000	4.200	4.200
BOATTAIL END	62.220	3.500	3.500

LONGITUDINAL DISTANCE FROM INLET LEADING EDGE TO
DIVERTER LEADING EDGE = 0.00

DIVERTER LENGTH = 18.87

HEIGHT OF DIVERTER LEADING EDGE = 0.30

Figure 26 Inlet Geometry Output

1

***** THE USAF AUTOMATED MISSILE DATCOM * REV 5/97 ***** CASE 1
 AERODYNAMIC METHODS FOR MISSILE CONFIGURATIONS PAGE 6
 BASE-JET PLUME INTERACTION FLOW PARAMETERS

***** FLIGHT CONDITIONS AND REFERENCE QUANTITIES *****
 MACH NO = 2.36 REYNOLDS NO = 3.000E+06 /FT
 SIDESLIP = 0.00 DEG ROLL = 0.00 DEG
 REF AREA = 11.045 FT**2 MOMENT CENTER = 18.750 FT
 REF LENGTH = 3.75 FT LAT REF LENGTH = 3.75 FT

WARNING EXTRAPOLATION WILL BE REQUIRED FOR THE FOLLOWING CONDITIONS:

* ANGLE OF ATTACK GREATER THAN 8.0

ALPHA	----- BASE FLOW PARAMETERS -----				----- INCREMENTAL DATA -----		
	CP-BASE	CA-BASE	TB/TINF	PB/PINF	DEL CN	DEL CM	DEL CA
0.00	0.0828	-0.0162	5.9018	1.3226	0.0000	0.0000	-0.0010
4.00	0.0828	-0.0162	5.9018	1.3226	0.0004	-0.0028	-0.0010
8.00	0.0828	-0.0162	5.9018	1.3226	0.0009	-0.0057	-0.0010
12.00	0.0828	-0.0162	5.9018	1.3226	0.0013	-0.0085	-0.0010
16.00	0.0828	-0.0162	5.9018	1.3226	0.0017	-0.0113	-0.0010
20.00	0.0828	-0.0162	5.9018	1.3226	0.0022	-0.0142	-0.0010
24.00	0.0828	-0.0162	5.9018	1.3226	0.0026	-0.0170	-0.0010
28.00	0.0828	-0.0162	5.9018	1.3226	0.0030	-0.0198	-0.0010

Figure 27 Base-Jet Plume Interaction Output

***** FLIGHT CONDITIONS AND REFERENCE QUANTITIES *****
 MACH NO = 2.00 REYNOLDS NO = 1.414E+07 /FT
 ALTITUDE = 0.0 FT DYNAMIC PRESSURE = 5925.45 LB/FT**2
 SIDESLIP = 0.00 DEG ROLL = 0.00 DEG
 REF AREA = 38.485 FT**2 MOMENT CENTER = 80.800 FT
 REF LENGTH = 7.00 FT LAT REF LENGTH = 7.00 FT

PROTUBERANCE AXIAL FORCE COEFFICIENT IS CALCULATED AT ZERO ANGLE OF
 ATTACK AND ASSUMED CONSTANT FOR ALL ANGLES OF ATTACK. PROTUBERANCES
 ARE CONSIDERED PART OF THE BODY WHEN CALCULATING TOTAL AXIAL FORCE.
 PROTUBERANCE AXIAL FORCE IS INCLUDED IN THE TOTAL CONFIGURATION RESULTS.

----- PROTUBERANCE CALCULATIONS -----

NUMBER	TYPE	LONG. LOCATION (FT)	NUMBER	INDIVIDUAL CA	TOTAL CA
1	FAIRING	14.000	2	0.0605	0.1209
2	VERTICAL CYLINDER	22.000	4	0.0156	0.0622
3	LAUNCH SHOE	39.000	2	0.0332	0.0664
4	FLAT PLATE OR BLOCK	56.000	1	0.0086	0.0086

TOTAL CA DUE TO PROTUBERANCES = 0.2581

Figure 28 Protuberance Output

1

***** THE USAF AUTOMATED MISSILE DATCOM * REV 5/97 *****
 AERODYNAMIC METHODS FOR MISSILE CONFIGURATIONS
 PLANAR WING, CRUCIFORM PLUS TAIL CONFIGURATION
 BODY ALONE PARTIAL OUTPUT

CASE 1
 PAGE 6

***** FLIGHT CONDITIONS AND REFERENCE QUANTITIES *****
 MACH NO = 2.36 REYNOLDS NO = 3.000E+06 /FT
 SIDESLIP = 0.00 DEG ROLL = 0.00 DEG
 REF AREA = 11.045 IN**2 MOMENT CENTER = 18.750 IN
 REF LENGTH = 3.75 IN LAT REF LENGTH = 3.75 IN

ALPHA	CA-FRIC	CA-PRES/WAVE	CA-BASE	CA-PROT	CA-SEP	CA-ALP
0.00	0.0845	0.1030	0.1254			0.1254
4.00	0.0841	0.1029	0.1251			0.1251
8.00	0.0828	0.1024	0.1242			0.1242
12.00	0.0808	0.1017	0.1227			0.1227
16.00	0.0781	0.1007	0.1205			0.1205
20.00	0.0746	0.0994	0.1178			0.1178
24.00	0.0705	0.0978	0.1146			0.1146
28.00	0.0659	0.0960	0.1107			0.1107

CROSS FLOW DRAG PROPORTIONALITY FACTOR = 1.00000

ALPHA	CN-POTEN	CN-VISC	CN-SEP	CM-POTEN	CM-VISC	CM-SEP	CDC
0.00	0.000	0.000		0.000	0.000		0.740
4.00	0.221	0.047		0.582	-0.022		0.841
8.00	0.438	0.232		1.151	-0.108		1.044
12.00	0.644	0.665		1.693	-0.310		1.340
16.00	0.835	1.308		2.197	-0.610		1.500
20.00	1.007	2.005		2.650	-0.936		1.494
24.00	1.157	2.608		3.043	-1.218		1.374
28.00	1.280	3.330		3.367	-1.555		1.317

Figure 29 Body Alone Aerodynamic Partial Output

1

***** THE USAF AUTOMATED MISSILE DATCOM * REV 5/97 *****
 AERODYNAMIC METHODS FOR MISSILE CONFIGURATIONS
 PLANAR WING, CRUCIFORM PLUS TAIL CONFIGURATION
 FIN SET 2 CN, CM PARTIAL OUTPUT

CASE 1
 PAGE 10

***** FLIGHT CONDITIONS AND REFERENCE QUANTITIES *****
 MACH NO = 2.36 REYNOLDS NO = 3.000E+06 /FT
 SIDESLIP = 0.00 DEG ROLL = 0.00 DEG
 REF AREA = 11.045 IN**2 MOMENT CENTER = 18.750 IN
 REF LENGTH = 3.75 IN LAT REF LENGTH = 3.75 IN

NORMAL FORCE SLOPE AT ALPHA ZERO, CNA = 0.04956/DEG (1 PANEL)
 CENTER OF PRESSURE FOR LINEAR CN = -4.39078 (CALIBERS FROM C.G.)
 CENTER OF PRESSURE FOR NON-LINEAR CN = -4.42084 (CALIBERS FROM C.G.)

ALPHA	CN			CM		
	LINEAR	NON-LINEAR	TOTAL	LINEAR	NON-LINEAR	TOTAL
0.00	0.0000	0.0000	0.0000	0.0000	0.0000	0.0000
4.00	0.3952	0.0033	0.3985	-1.7351	-0.0146	-1.7497
8.00	0.7826	0.0264	0.8091	-3.4364	-0.1169	-3.5533
12.00	1.1549	0.0900	1.2449	-5.0709	-0.3980	-5.4689
16.00	1.5047	0.2185	1.7232	-6.6066	-0.9661	-7.5727
20.00	1.8251	0.3375	2.1626	-8.0138	-1.4919	-9.5056
24.00	2.1101	0.4759	2.5860	-9.2649	-2.1041	-11.3690
28.00	2.3540	0.6323	2.9863	-10.3358	-2.7955	-13.1313

Figure 30 Fin Normal Force and Pitching Moment Partial Output

1

***** THE USAF AUTOMATED MISSILE DATCOM * REV 5/97 *****
 AERODYNAMIC METHODS FOR MISSILE CONFIGURATIONS
 PLANAR WING, CRUCIFORM PLUS TAIL CONFIGURATION
 FIN SET 2 CA PARTIAL OUTPUT

CASE 1
 PAGE 9

***** FLIGHT CONDITIONS AND REFERENCE QUANTITIES *****
 MACH NO = 2.36 REYNOLDS NO = 3.000E+06 /FT
 SIDESLIP = 0.00 DEG ROLL = 0.00 DEG
 REF AREA = 11.045 IN**2 MOMENT CENTER = 18.750 IN
 REF LENGTH = 3.75 IN LAT REF LENGTH = 3.75 IN

SINGLE FIN PANEL ZERO-LIFT AXIAL FORCE COMPONENTS

SKIN FRICTION 0.0116
 SUBSONIC PRESSURE 0.0000
 TRANSONIC WAVE 0.0000
 SUPERSONIC WAVE 0.0092
 LEADING EDGE 0.0096
 TRAILING EDGE 0.0000
 TOTAL CAO 0.0304

FIN AXIAL FORCE DUE TO ANGLE OF ATTACK

ALPHA	CA DUE TO LIFT (SINGLE PANEL)	CA-TOTAL (4 FINS)
0.00	0.0000	0.1217
4.00	0.0000	0.1214
8.00	0.0000	0.1205
12.00	0.0000	0.1191
16.00	0.0000	0.1170
20.00	0.0000	0.1144
24.00	0.0000	0.1112
28.00	0.0000	0.1075

Figure 31 Fin Axial Force Partial Output

1

***** THE USAF AUTOMATED MISSILE DATCOM * REV 5/97 *****
AERODYNAMIC METHODS FOR MISSILE CONFIGURATIONS
NACA 64A206 AIRFOIL SECTION CHECK
FIN SET 1SECTION AERODYNAMICS

CASE 1
PAGE 6

IDEAL ANGLE OF ATTACK = 0.0386 DEG.
ZERO LIFT ANGLE OF ATTACK = -1.5789 DEG.
IDEAL LIFT COEFFICIENT = 0.1902
ZERO LIFT PITCHING MOMENT COEFFICIENT = -0.0470
MACH ZERO LIFT-CURVE-SLOPE = 0.1039 /DEG.
LEADING EDGE RADIUS = 0.0025 FRACTION CHORD
MAXIMUM AIRFOIL THICKNESS = 0.0600 FRACTION CHORD
DELTA-Y = 1.1715 PERCENT CHORD

MACH = 0.200	CL-ALPHA = 0.1146 /DEG.	XAC = 0.2469	CL MAX = 1.0285
MACH = 0.400	CL-ALPHA = 0.1230 /DEG.	XAC = 0.2483	CL MAX = 1.0995
MACH = 0.500	CL-ALPHA = 0.1297 /DEG.	XAC = 0.2496	CL MAX = 1.1350
MACH = 0.600	CL-ALPHA = 0.1393 /DEG.	XAC = 0.2515	CL MAX = 1.1705
MACH = 0.700	CL-ALPHA = 0.1540 /DEG.	XAC = 0.2548	CL MAX = 1.2060

*** CREST CRITICAL MACH NUMBER EXCEEDED ***

CREST CRITICAL MACH = 0.7475
LOCATION = 0.3366 FRACTION CHORD
LIFT-CURVE-SLOPE = 0.1347 /DEG.

Figure 32 Airfoil Section Aerodynamic Partial Output

***** FLIGHT CONDITIONS AND REFERENCE QUANTITIES *****

MACH NO =	2.00	REYNOLDS NO =	1.414E+07 /FT
ALTITUDE =	0.0 FT	DYNAMIC PRESSURE =	5925.45 LB/FT**2
SIDESLIP =	0.00 DEG	ROLL =	0.00 DEG
REF AREA =	38.485 FT**2	MOMENT CENTER =	80.800 FT
REF LENGTH =	7.00 FT	LAT REF LENGTH =	7.00 FT

ALPHA	CN-INLT	CM-INLT	CA-INLT	CA-ADD	CY-INLT	CLN-INLT	CLL-INLT
0.00	0.0000	-0.0482	0.0854		0.0000	0.0000	0.0000
2.00	0.1588	-0.3610	0.0854		0.0000	0.0000	0.0000
4.00	0.3354	-0.7725	0.0854		0.0000	0.0000	0.0000
6.00	0.5293	-1.2816	0.0854		0.0000	0.0000	0.0000
8.00	0.7414	-1.8964	0.0854		0.0000	0.0000	0.0000
10.00	0.9711	-2.6154	0.0854		0.0000	0.0000	0.0000
12.00	1.2210	-3.4545	0.0854		0.0000	0.0000	0.0000
16.00	1.8098	-5.6565	0.0854		0.0000	0.0000	0.0000
20.00	2.4688	-8.3086	0.0854		0.0000	0.0000	0.0000
24.00	3.1660	-11.2537	0.0854		0.0000	0.0000	0.0000
28.00	3.7624	-13.7545	0.0854		0.0000	0.0000	0.0000

Figure 33 Inlet Aerodynamic Partial Output

1

***** THE USAF AUTOMATED MISSILE DATCOM * REV 5/97 *****
AERODYNAMIC METHODS FOR MISSILE CONFIGURATIONS
PLANAR WING, CRUCIFORM PLUS TAIL CONFIGURATION
AERODYNAMIC FORCE AND MOMENT SYNTHESIS

CASE 1
PAGE 12

***** FLIGHT CONDITIONS AND REFERENCE QUANTITIES *****
MACH NO = 2.36 REYNOLDS NO = 3.000E+06 /FT
SIDESLIP = 0.00 DEG ROLL = 0.00 DEG
REF AREA = 11.045 IN**2 MOMENT CENTER = 18.750 IN
REF LENGTH = 3.75 IN LAT REF LENGTH = 3.75 IN

-----FIN SET 2 IN PRESENCE OF THE BODY-----

ALPHA	CN	CM	CA	CY	CLN	CLL
0.00	0.0000	0.0000	0.1217	0.0000	0.0000	0.0000
4.00	0.3934	-1.7272	0.1217	0.0000	0.0000	0.0000
8.00	0.7753	-3.4042	0.1217	0.0000	0.0000	0.0000
12.00	1.1790	-5.1767	0.1217	0.0000	0.0000	0.0000
16.00	1.5721	-6.9029	0.1217	0.0000	0.0000	0.0000
20.00	1.9600	-8.6060	0.1217	0.0000	0.0000	0.0000
24.00	2.3304	-10.2322	0.1217	0.0000	0.0000	0.0000
28.00	2.6810	-11.7717	0.1217	0.0000	0.0000	0.0000

Figure 34 Fin Set in Presence of the Body Partial Output

1

***** THE USAF AUTOMATED MISSILE DATCOM * REV 5/97 *****
 AERODYNAMIC METHODS FOR MISSILE CONFIGURATIONS
 PLANAR WING, CRUCIFORM PLUS TAIL CONFIGURATION
 AERODYNAMIC FORCE AND MOMENT SYNTHESIS

CASE 1
 PAGE 14

***** FLIGHT CONDITIONS AND REFERENCE QUANTITIES *****
 MACH NO = 2.36 REYNOLDS NO = 3.000E+06 /FT
 SIDESLIP = 0.00 DEG ROLL = 0.00 DEG
 REF AREA = 11.045 IN**2 MOMENT CENTER = 18.750 IN
 REF LENGTH = 3.75 IN LAT REF LENGTH = 3.75 IN

-----FIN SET 2 PANEL CHARACTERISTICS-----

ALPHA	PANEL	AEQ (PANEL AXIS SYS.)	PANEL CN
0.00	1	0.0000	0.0000
0.00	2	0.0000	0.0000
0.00	3	0.0000	0.0000
0.00	4	0.0000	0.0000
4.00	1	0.0000	0.0000
4.00	2	3.9491	0.1967
4.00	3	0.0000	0.0000
4.00	4	-3.9491	-0.1967
8.00	1	0.0000	0.0000
8.00	2	7.6781	0.3877
8.00	3	0.0000	0.0000
8.00	4	-7.6781	-0.3877
12.00	1	0.0000	0.0000
12.00	2	11.4134	0.5895
12.00	3	0.0000	0.0000
12.00	4	-11.4134	-0.5895
16.00	1	0.0000	0.0000
16.00	2	14.7634	0.7861
16.00	3	0.0000	0.0000
16.00	4	-14.7634	-0.7861
20.00	1	0.0000	0.0000
20.00	2	18.1403	0.9800
20.00	3	0.0000	0.0000
20.00	4	-18.1403	-0.9800
24.00	1	0.0000	0.0000
24.00	2	21.5607	1.1652
24.00	3	0.0000	0.0000
24.00	4	-21.5607	-1.1652
28.00	1	0.0000	0.0000
28.00	2	24.9264	1.3405
28.00	3	0.0000	0.0000
28.00	4	-24.9264	-1.3405

Figure 35 Fin Set in Presence of the Body Partial Output (continued)

1

***** THE USAF AUTOMATED MISSILE DATCOM * REV 5/97 *****
AERODYNAMIC METHODS FOR MISSILE CONFIGURATIONS
PLANAR WING, CRUCIFORM PLUS TAIL CONFIGURATION
AERODYNAMIC FORCE AND MOMENT SYNTHESIS

CASE 1
PAGE 15

***** FLIGHT CONDITIONS AND REFERENCE QUANTITIES *****
MACH NO = 2.36 REYNOLDS NO = 3.000E+06 /FT
SIDESLIP = 0.00 DEG ROLL = 0.00 DEG
REF AREA = 11.045 IN**2 MOMENT CENTER = 18.750 IN
REF LENGTH = 3.75 IN LAT REF LENGTH = 3.75 IN

CARRYOVER INTERFERENCE FACTORS - FIN SET 1

ALPHA	K-W(B)	K-B(W)	KK-W(B)	KK-B(W)	XCP-W(B)	XCP-B(W)	Y-CP/(B/2)
0.00	1.4037	0.4360	0.9347	0.3658	0.3555	1.0903	0.4055
4.00	1.3649	0.4360	0.9347	0.3658	0.3555	1.0903	0.3730
8.00	1.3042	0.4360	0.9347	0.3658	0.3555	1.0903	0.3524
12.00	1.2421	0.4360	0.9347	0.3658	0.3555	1.0903	0.3396
16.00	1.1870	0.4360	0.9347	0.3658	0.3555	1.0903	0.3327
20.00	1.1423	0.4360	0.9347	0.3658	0.3555	1.0903	0.3297
24.00	1.1084	0.4360	0.9347	0.3658	0.3555	1.0903	0.3267
28.00	1.0840	0.4360	0.9347	0.3658	0.3555	1.0903	0.3253

Figure 36 Carryover Interference Factors Partial Output

```

1          ***** THE USAF AUTOMATED MISSILE DATCOM * REV 5/97 ***** CASE 1
              AERODYNAMIC METHODS FOR MISSILE CONFIGURATIONS PAGE 18
              PLANAR WING, CRUCIFORM PLUS TAIL CONFIGURATION
              FIN SET 2 PANEL BENDING MOMENTS (ABOUT EXPOSED ROOT CHORD)

```

```

          ***** FLIGHT CONDITIONS AND REFERENCE QUANTITIES *****
MACH NO = 2.36 REYNOLDS NO = 3.000E+06 /FT
SIDESLIP = 0.00 DEG ROLL = 0.00 DEG
REF AREA = 11.045 IN**2 MOMENT CENTER = 18.750 IN
REF LENGTH = 3.75 IN LAT REF LENGTH = 3.75 IN

```

ALPHA	PANL 1	PANL 2	PANL 3	PANL 4	PANL 5	PANL 6	PANL 7	PANL 8
0.0	0.00E+00	0.00E+00	0.00E+00	0.00E+00	0.00E+00			
4.0	-5.82E-10	9.81E-02	1.77E-08	-9.81E-02				
8.0	2.23E-09	1.95E-01	3.69E-08	-1.95E-01				
12.0	1.05E-09	2.98E-01	4.88E-08	-2.98E-01				
16.0	-1.85E-08	3.98E-01	8.32E-08	-3.98E-01				
20.0	3.35E-08	4.93E-01	1.17E-07	-4.93E-01				
24.0	9.57E-09	5.82E-01	1.45E-07	-5.82E-01				
28.0	-5.80E-09	6.66E-01	1.13E-07	-6.66E-01				

Figure 37 Panel Bending Moment Partial Output

```

1          ***** THE USAF AUTOMATED MISSILE DATCOM * REV 5/97 ***** CASE 1
              AERODYNAMIC METHODS FOR MISSILE CONFIGURATIONS PAGE 20
              PLANAR WING, CRUCIFORM PLUS TAIL CONFIGURATION
              FIN SET 2 PANEL HINGE MOMENTS (ABOUT HINGE LINE)

```

```

          ***** FLIGHT CONDITIONS AND REFERENCE QUANTITIES *****
MACH NO = 2.36 REYNOLDS NO = 3.000E+06 /FT
SIDESLIP = 0.00 DEG ROLL = 0.00 DEG
REF AREA = 11.045 IN**2 MOMENT CENTER = 18.750 IN
REF LENGTH = 3.75 IN LAT REF LENGTH = 3.75 IN

```

ALPHA	PANL 1	PANL 2	PANL 3	PANL 4	PANL 5	PANL 6	PANL 7	PANL 8
0.0	0.00E+00	0.00E+00	0.00E+00	0.00E+00				
4.0	6.18E-11	-1.08E-02	-1.88E-09	1.08E-02				
8.0	-2.35E-10	-2.20E-02	-3.88E-09	2.20E-02				
12.0	-1.10E-10	-3.46E-02	-5.11E-09	3.46E-02				
16.0	1.94E-09	-4.75E-02	-8.71E-09	4.75E-02				
20.0	-3.52E-09	-6.08E-02	-1.23E-08	6.08E-02				
24.0	-1.01E-09	-7.42E-02	-1.54E-08	7.42E-02				
28.0	6.18E-10	-8.73E-02	-1.20E-08	8.73E-02				

Figure 38 Panel Hinge Moment Partial Output

1 ***** THE USAF AUTOMATED MISSILE DATCOM * REV 5/97 ***** CASE 1
 AERODYNAMIC METHODS FOR MISSILE CONFIGURATIONS PAGE 25
 PLANAR WING, CRUCIFORM PLUS TAIL CONFIGURATION
 BODY + 2 FIN SETS DYNAMIC DERIVATIVES

***** FLIGHT CONDITIONS AND REFERENCE QUANTITIES *****
 MACH NO = 2.36 REYNOLDS NO = 3.000E+06 /FT
 SIDESLIP = 0.00 DEG ROLL = 0.00 DEG
 REF AREA = 11.045 IN**2 MOMENT CENTER = 18.750 IN
 REF LENGTH = 3.75 IN LAT REF LENGTH = 3.75 IN

----- DYNAMIC DERIVATIVES (PER DEGREE) -----

ALPHA	CNQ	CMQ	CAQ	CNAD	CMAD
0.00	1.632	-6.739	0.000	0.835	-1.654
4.00	1.653	-6.808	0.000	0.835	-1.654
8.00	1.602	-6.598	0.000	0.835	-1.654
12.00	1.522	-6.280	0.000	0.835	-1.654
16.00	1.411	-5.822	0.000	0.835	-1.654
20.00	1.302	-5.374	0.000	0.835	-1.654
24.00	1.203	-4.974	0.000	0.835	-1.654
28.00	1.106	-4.574	0.000	0.835	-1.654

PITCH RATE DERIVATIVES NON-DIMENSIONALIZED BY Q*LREF/2*V
 1 ***** THE USAF AUTOMATED MISSILE DATCOM * REV 5/97 ***** CASE 1
 AERODYNAMIC METHODS FOR MISSILE CONFIGURATIONS PAGE 26
 PLANAR WING, CRUCIFORM PLUS TAIL CONFIGURATION
 BODY + 2 FIN SETS DYNAMIC DERIVATIVES

***** FLIGHT CONDITIONS AND REFERENCE QUANTITIES *****
 MACH NO = 2.36 REYNOLDS NO = 3.000E+06 /FT
 SIDESLIP = 0.00 DEG ROLL = 0.00 DEG
 REF AREA = 11.045 IN**2 MOMENT CENTER = 18.750 IN
 REF LENGTH = 3.75 IN LAT REF LENGTH = 3.75 IN

----- DYNAMIC DERIVATIVES (PER DEGREE) -----

ALPHA	CYR	CLNR	CLLR	CYP	CLNP	CLLP
0.00	1.597	-6.910	0.000	0.000	0.000	-0.422
4.00	1.564	-6.764	0.000	0.004	-0.019	-0.419
8.00	1.517	-6.558	0.000	0.009	-0.039	-0.420
12.00	1.475	-6.372	0.000	0.012	-0.055	-0.429
16.00	1.444	-6.240	0.000	0.015	-0.067	-0.437
20.00	1.429	-6.173	0.000	0.016	-0.072	-0.410
24.00	1.430	-6.178	0.000	0.016	-0.068	-0.396
28.00	1.447	-6.253	0.000	0.014	-0.062	-0.379

YAW AND ROLL RATE DERIVATIVES NON-DIMENSIONALIZED BY R*LATREF/2*V

Figure 39 Dynamic Derivative Output

4.3 EXTERNAL DATA FILES

4.3.1 Total Force and Moment PLOT Data

The code has the capability to be used in conjunction with other missile design tools, such as post-processing plotting programs or trajectory programs. Fixed format aerodynamic data is output as an external data file with the addition of the PLOT control card. The PLOT data are written to file “for003.dat”. Included in this data file are the six component forces and moments based upon the user specified reference quantities. In order to print component buildup data to the plot file the BUILD and PLOT control cards must be present in the case. If TRIM calculations were performed, the PLOT file also includes the control deflection for trim. Examples of the PLOT file format are shown in Figures 40-41.

An option to create a user specified format data file is also available. The control cards WRITE and FORMAT have been designed for easy access to this capability. Output generated from the WRITE control is written to file “for004.dat”. Tables 18-26 show the array names and elements for data that can be output using the WRITE controls.

4.3.2 Pressure Distribution Data

If the Mach number is supersonic ($M > 1.2$), the user has the option to print the surface pressure distributions over the body and fins. This option is selected only through the addition of the control card PRESSURES. Since three body alone supersonic methods are available (Van Dyke Hybrid, Second-Order Shock Expansion (SOSE), and Newtonian flow) the capability exists to output the pressure distribution data from any one of these methods. The method to be used in the calculation of the pressure data is controlled with the control cards SOSE and HYPER; if neither control card is input, the Van Dyke Hybrid method is selected unless it is not valid for the case. Because of the nature of the calculations, body alone pressures are printed for angles of attack less than or equal to 15 degrees when using the Hybrid or SOSE techniques.

The primary body pressure distribution output is written to file “for010.dat”. An example of the file format is shown in Figure 42. Local Mach number data is computed using the SOSE method only, and is written to file “for012.dat” if the PRESSURES option is used. An example of the file format is shown in Figure 43. All body pressure distribution data is based on a configuration that has body diameter of unity; that is, the configuration is expressed in calibers (or body diameters). The longitudinal stations at which pressure coefficient data is desired cannot be user specified; however, sufficient data is provided to permit accurate interpolation for most applications.

The capability also exists for the user to output the pressure distribution data over fins at any Mach number greater than 1.05. This option is also controlled by the PRESSURES control card. Due to the nature of the method, only pressure distribution data at zero angle of attack is presently output. The fin pressure data is written to file “for011.dat”. An example of the file format is shown in Figure 44.

```

VARIABLES=ALPHA,CN,CM,CA,CY,CLN,CLL,DELTA
ZONE T="NO TRIM MACH= 2.36"
  0.0000  0.0000  0.0000  0.3774  0.0000  0.0000  0.0000  0.0000
  4.0000  1.1792 -1.5768  0.3768  0.0000  0.0000  0.0000  0.0000
  8.0000  2.4758 -3.1936  0.3749  0.0000  0.0000  0.0000  0.0000
 12.0000  3.9924 -5.0559  0.3718  0.0000  0.0000  0.0000  0.0000
 16.0000  5.5819 -6.9624  0.3674  0.0000  0.0000  0.0000  0.0000
 20.0000  7.1514 -8.9039  0.3619  0.0000  0.0000  0.0000  0.0000
 24.0000  8.6014 -10.7919  0.3552  0.0000  0.0000  0.0000  0.0000
 28.0000 10.0926 -12.6922  0.3476  0.0000  0.0000  0.0000  0.0000

```

Figure 40 Configuration Aerodynamics Plot File Output ("for003.dat")

```

VARIABLES=ALPHA,CN,CM,CA,CY,CLN,CLL,DELTA
ZONE T="TRIMMED MACH= 2.36"
  0.00  0.0000  0.0000  0.3774  0.0000  0.0000  0.0000  0.0000
  4.00  0.8208  0.0000  0.3796  0.0000  0.0000  0.0000 -3.7736
  8.00  1.7500  0.0000  0.3697  0.0000  0.0000  0.0000 -7.4899
 12.00  2.8434  0.0000  0.3526  0.0000  0.0000  0.0000 -11.4976
 16.00  3.9999  0.0000  0.3314  0.0000  0.0000  0.0000 -15.2325
 20.00  5.1284  0.0000  0.3213  0.0000  0.0000  0.0000 -19.1469
 24.00  6.1496  0.0000  0.3124  0.0000  0.0000  0.0000 -23.1731
 28.00  0.0000  0.0000  0.0000  0.0000  0.0000  0.0000  0.0000

```

Figure 41 Trimmed Aerodynamics Plot File Output ("for003.dat")

```

VARIABLES=X/D,CP(0),CP(30),CP(60),CP(90),CP(120),CP(150),CP(180)
ZONE T="BODY CP AT MACH= 2.36 ALPHA= 0.00"
  0.000000  0.28444  0.28444  0.28444  0.28444  0.28444  0.28444  0.28444
  0.050000  0.27667  0.27667  0.27667  0.27667  0.27667  0.27667  0.27667
  0.100000  0.26856  0.26856  0.26856  0.26856  0.26856  0.26856  0.26856
  0.150000  0.26066  0.26066  0.26066  0.26066  0.26066  0.26066  0.26066
  0.200000  0.25279  0.25279  0.25279  0.25279  0.25279  0.25279  0.25279
  0.250000  0.24500  0.24500  0.24500  0.24500  0.24500  0.24500  0.24500
  0.300000  0.23728  0.23728  0.23728  0.23728  0.23728  0.23728  0.23728
  0.350000  0.22963  0.22963  0.22963  0.22963  0.22963  0.22963  0.22963
  0.400000  0.22206  0.22206  0.22206  0.22206  0.22206  0.22206  0.22206
  0.450000  0.21456  0.21456  0.21456  0.21456  0.21456  0.21456  0.21456
  0.500000  0.20742  0.20742  0.20742  0.20742  0.20742  0.20742  0.20742

```

Figure 42 Body Pressure Distribution Plot File Output ("for010.dat")

```

VARIABLES=Y/(B/2),X/C,CP
ZONE T="FIN SET 1 CP, MACH= 2.36"
0.00003 0.00000 0.34127
0.00003 0.00003 0.33098
0.00003 0.00013 0.30135
0.00003 0.00029 0.25595
0.00003 0.00050 0.20026
0.00003 0.00077 0.14100
0.00003 0.00108 0.08532
0.00003 0.00142 0.03992
0.00003 0.00234 0.16288
0.00003 0.00247 0.11436
0.00003 0.00261 0.10329
0.00003 0.00275 0.09244
0.00003 0.00290 0.08167
0.00003 0.00305 0.07097
0.00003 0.00321 0.06031
0.00003 0.00337 0.04969
0.00003 0.00354 0.03911
0.00003 0.00372 0.02854
0.00003 0.00389 0.01560
0.00003 0.00390 0.04422
0.00003 0.00390 0.04422

```

Figure 43 Fin Pressure Distribution Plot File Output (“for011.dat”)

```

VARIABLES=X/D,CP,MACH
ZONE T="BODY CP, MLOCAL AT MACH= 2.36 ALPHA= 0.0"
0.000000 0.284442 1.867502
0.050000 0.276666 1.876899
0.100000 0.268558 1.886836
0.150000 0.260664 1.896650
0.200000 0.252793 1.906577
0.250000 0.244998 1.916552
0.300000 0.237278 1.926578
0.350000 0.229630 1.936658
0.400000 0.222056 1.946790
0.450000 0.214556 1.956975
0.500000 0.207422 1.966809

```

Figure 44 Body Pressure and Local Mach Number Plot File Output (“for012.dat”)

4.4 ARRAY DUMPS

When it is necessary to examine the values stored in internal data arrays the DUMP control card can be used. This control card causes the contents of the named data arrays to be printed to file "for006.dat". Array dumps are provided for each Mach number of the input case, and represent the data block contents at aerodynamic calculation completion.

Note that all data arrays are initialized to a constant named "UNUSED", which is preset to a value of 1×10^{-30} . Hence, any array element which contains this constant was not changed during execution of the case (since it is highly unlikely that this constant will result from any calculation). This scheme permits rapid "tracking" of program calculation sequences while in "debug" mode. Tables 18-26 show the array names and elements for data that can be output using the DUMP. Unless otherwise noted, all variables within arrays are functions of angle of attack.

Table 18 Body Aerodynamic Work Array Names and Elements

Configuration	DUMP array name	WRITE array name
Body	BDWK	BDWORK

Array location	Variable	Definition	Units
1-20	CNP	Potential normal force coefficient	-
21-40	CMP	Potential pitching moment coefficient	-
41-60	CNVIS	Viscous normal force coefficient	-
61-80	CMVIS	Viscous pitching moment coefficient	-
81-100	CAPR	Pressure/wave axial force coefficient	-
101-120	CAF	Friction axial force coefficient	-
121-140	CABASE	Base axial force coefficient	-
141	ETA	Cross-flow drag proportionality factor	-
142-161	CDC	Cross-flow drag coefficient	-
162-181	CAPROT	Protuberance axial force coefficient	-
182-201	BOTDCA	Axial force coefficient increment due to plume separation	-
202-221	BOTDCN	Normal force coefficient increment due to plume separation	-
222-241	BOTDCM	Pitching moment coefficient increment due to plume separation	-

Table 19 Fin Aerodynamic Work Array Names and Elements

Configuration	DUMP array name	WRITE array name
Fin 1	F1WK	F1WORK
Fin 2	F2WK	F2WORK
Fin 3	F3WK	F3WORK
Fin 4	F4WK	F4WORK

Array location	Variable	Definition	Units
1	RHO	Panel effective L.E. radius	ft
2	TMAX	Panel effective maximum t/c	-
3	KSHAR	Airfoil section wave drag parameter	-
4-23	CCLA	Airfoil section lift curve slope vs Mach number	1/deg
24-43	XAC	Airfoil section aerodynamic center vs Mach number	-
44-63	CMCO4	Airfoil section c/4 pitching moment coefficient	-
64	CNALF	Single panel normal force slope, CAN	1/deg
65-84	CNAAF	Single panel CNAA vs angle of attack	1/rad**2
85-104	CNLF	Total fin set linear normal force coefficient	-
105-124	CNNLF	Total fin set non-linear normal force coefficient	-
125-144	CNF	Total fin set normal force coefficient	-
145	XCPL	Single panel linear center of pressure	ft
146	XCPNL	Single panel non-linear center of pressure	ft
147-166	CMFL	Total fin set linear pitching moment coefficient	
167-186	CMFNL	Total fin set non-linear pitching moment coefficient	
187-206	CMF	Total fin set pitching moment coefficient	
207	CAO	Single panel axial force at zero angle of attack	
208-227	CANLF	Single panel axial force vs angle of attack	
227-247	ALPTF	Interpolated angles of attack for panel characteristics	deg
248-267	CNFT	Interpolated CN for panel characteristics	
268	AI	Airfoil section ideal angle of attack	deg
269	AO	Airfoil section zero lift angle of attack	deg
270	CLI	Airfoil section ideal CL	-
271-290	CLMAX	Airfoil section CLMAX vs Mach number	-

Table 20 Inlet Incremental Data Array Names and Elements

Configuration	DUMP array name	WRITE array name
Inlet	INLD	INLTD

Array location	Variable	Definition	Units
1-20	CNI	Inlet increment to normal force coefficient	-
21-40	CMI	Inlet increment to pitching moment coefficient	-
41-60	CAI	Inlet increment to axial force coefficient	-
61-80	CYI	Inlet increment to side force coefficient	-
81-100	CLNI	Inlet increment to yawing moment coefficient	-
101-120	CLLI	Inlet increment to rolling moment coefficient	-

Table 21 Static Coefficient and Derivative Data Array Names and Elements

Configuration	DUMP array name	WRITE array name
Body alone	SBODY	SBODY
Fin 1 alone	SF1	SFIN1
Fin 1 alone	SF2	SFIN2
Fin 3 alone	SF3	SFIN3
Fin 4 alone	SF4	SFIN4
Body + 1 fin set	SB1	SB1
Body + 2 fin sets	SB12	SB12
Body + 3 fin sets	SB13	SB123
Body + 4 fin sets	SB14	SB1234

Array location	Variable	Definition	Units
1-20	CN	Normal force coefficient	-
21-40	CM	Pitching moment coefficient	-
41-60	CA	Axial force coefficient	-
61-80	CY	Side force coefficient	-
81-100	CLN	Yawing moment coefficient	-
101-120	CLL	Rolling moment coefficient	-
121-140	CNA	Normal force derivative with angle of attack	1/deg
141-160	CMA	Pitching moment derivative with angle of attack	1/deg
161-180	CYB	Side force derivative with sideslip angle	1/deg
181-200	CNB	Yawing moment derivative with sideslip angle	1/deg
201-220	CLB	Rolling moment derivative with sideslip angle	1/deg

Table 22 Dynamic Derivative Data Array Names and Elements

Configuration	DUMP array name	WRITE array name
Body alone	DBODY	DBODY
Body + 1 fin set	DB1	DB1
Body + 2 fin sets	DB12	DB12
Body + 3 fin sets	DB13	DB123
Body + 4 fin sets	DB14	DB1234

Array location	Variable	Definition	Units
1-20	CNQ	Normal force due to pitch rate	1/deg
21-40	CMQ	Pitching moment due to pitch rate	1/deg
41-60	CAQ	Axial force due to pitch rate	1/deg
61-80	CYQ	Side force due to pitch rate	1/deg
81-100	CLNQ	Yawing moment due to pitch rate	1/deg
101-120	CLLQ	Rolling moment due to pitch rate	1/deg
121-140	CNR	Normal force due to yaw rate	1/deg
141-160	CMR	Pitching moment due to yaw rate	1/deg
161-180	CAR	Axial force due to yaw rate	1/deg
181-200	CYR	Side force due to yaw rate	1/deg
201-220	CLNR	Yawing moment due to yaw rate	1/deg
221-240	CLLR	Rolling moment due to yaw rate	1/deg
241-260	CNP	Normal force due to roll rate	1/deg
261-280	CMP	Pitching moment due to roll rate	1/deg
281-300	CAP	Axial force due to roll rate	1/deg
301-320	CYP	Side force due to roll rate	1/deg
321-340	CLNP	Yawing moment due to roll rate	1/deg
341-360	CLLP	Rolling moment due to roll rate	1/deg
361-380	CNAD	Normal force due to rate of change of alpha	1/deg
381-400	CMAD	Pitching moment due to rate of change of alpha	1/deg

Table 23 Trimmed Aerodynamic Data Array Names and Elements

Configuration	DUMP array name	WRITE array name
Trimmed	-	TRIMD

Array location	Variable	Definition	Units
1-20	DELTRM	Control deflection for trim	deg
21-40	CNTRM	Trimmed normal force coefficient	-
41-60	CATRM	Trimmed axial force coefficient	-
61-80	CYTRM	Trimmed side force coefficient	-
81-100	CLNTRM	Trimmed yawing moment coefficient	-
101-120	CLLTRM	Trimmed rolling moment coefficient	-

Table 24 Untrimmed Aerodynamic Data Array Names and Elements

Configuration	DUMP array name	WRITE array name
Untrimmed	-	UTRIMD

Array location	Variable	Definition	Units
1-20	CN	Normal force coefficient for delta 1	-
21-40		Normal force coefficient for delta 2	-
41-60		Normal force coefficient for delta 3	-
61-80		Normal force coefficient for delta 4	-
81-100		Normal force coefficient for delta 5	-
101-120		Normal force coefficient for delta 6	-
121-140		Normal force coefficient for delta 7	-
141-160		Normal force coefficient for delta 8	-
161-180		Normal force coefficient for delta 9	-
181-200		Normal force coefficient for delta 10	-
201-400	CM	Pitching moment coefficient (see CN pattern)	-
401-600	CA	Axial force coefficient (see CN pattern)	-
601-800	CY	Side force coefficient (see CN pattern)	-
801-1000	CLN	Yawing moment coefficient (see CN pattern)	-
1001-1200	CLL	Rolling moment coefficient (see CN pattern)	-

Table 25 Flight Condition Data Array Names and Elements

Configuration	DUMP array name	WRITE array name
-	FLT	FLC

Array location	Variable	Definition	Units
1	NALPHA	Number of angles of attack	-
2-21	ALPHA	Angle of attack	deg
22	BETA	Sideslip angle	deg
23	PHI	Roll angle	deg
24	NMACH	Number of Mach numbers	-
25-44	MACH	Mach numbers	-
45-65	ALT	Altitudes	ft
66-85	REN	Reynolds numbers	1/ft
86-105	VINF	Free-stream velocities	ft/sec
106-125	TINF	Free-stream static temperatures	R
126-145	PINF	Free-stream static pressures	lb/ft ²

Table 26 Configuration Attitude Data Array Names and Elements

Configuration	DUMP array name	WRITE array name
-	FLCT	TOTALC

Array location	Variable	Definition	Units
1-20	BALPHA	Body axis angles of attack	deg
21-40	BBETA	Body axis sideslip angles	deg
41-60	BPHI	Body axis roll angle	deg
61-80	ALPTOT	Total angle of attack	deg

5.0 AERODYNAMIC METHODOLOGY

This section briefly summarizes the method routines incorporated in the Missile Datcom code. Also covered in this section is the means to update or replace a method.

5.1 METHODS INCORPORATED

The methods incorporated are summarized in tables at the end of this section. Each method is coded into its own subroutine so that revision or replacement is easily accomplished. The program subroutines corresponding to the methods are also given. In many cases, multiple subroutines are shown for a given parameter. These indicate the program calling sequence, with the first subroutine listed as the "bottom" level routine. Detailed documentation within the code using "comment cards" further describe the methods as well as their limitations.

5.2 CHANGING A METHOD

Replacing a component buildup method is easily done. Since each method is coded in an individual subroutine, simply replacing the method subroutine will implement the new technique. A few of the methods are complex and require several subroutines; these are called method modules. Method modules substitution is more complex but can still be easily accomplished. The program development philosophy, described below, will aid in method revision.

Code Structure: The code was developed using top-down design. This development scheme was implemented by coding at the top-most control logic downward to integration of the individual method subroutines. Hence, the upper levels of the code structure contain the basic logic to implement the component buildup methods. The lower levels are the implemented methods. In most cases the control logic requires no changes.

Method Coding Style: Most Methods are implemented in a single subroutine. Their inputs and outputs are passed through the subroutine calling sequence. Any method routine can be extracted and used in another code without modification. In some cases utility routines, such as table look-ups, are used; they must also be extracted if the method is to be used in another code.

Each subroutine includes a brief description of the inputs and outputs, the reference documentation, and any limitations or assumptions.

Execution Sequence: Subroutines BODY and FINS control the calculation sequence for body alone and fin alone, respectively. These two routines are called by the master aerodynamic calculation subroutine AERO; this is where the Mach number and the flight conditions are defined for the user input case. the full configuration component build-up is done in subroutine SYNTHS.

The aerodynamics are calculated in the following sequence: 1) Normal force, 2) Axial force, 3) Pitching Moment, 4) Side Force, 5) Yawing Moment, 6) Rolling Moment, and 7) the derivatives of the above with respect to angle of attack and sideslip angle. In some cases, the calling sequence must not be changed since subsequent results are dependant upon other coefficients. For example, drag-to-lift is dependant upon normal force. Extreme caution must be exercised when revising the

method execution sequence. It is recommended that the same example case be run with both the "old" and "new" versions of the code and any differences be reconciled.

Special options of the code such as experimental data substitution and configuration incrementing depend on the methods by which the aerodynamic coefficients are calculated. Both of these Options are executed in the subroutine SYNTHS. An example of these options dependence on the computation methods is the separation of C_N into C_{N_0} , C_{N_p} , and C_{N_v} . Incrementing factors are applied to each of these components separately. Therefore, a change in the decomposition of C_N would effect the configuration incrementing option. Therefore any change in the method of computing an aerodynamic coefficient should be checked for synthesis ramifications.

Changing a Method Subroutine: Revising a method which is coded into a single subroutine is as simple as writing a routine with the same name and substituting it into the program. Any changes to the variables passed through the routine calling sequence must also be changed in those routines that call it. Data required which are not available in the calling sequence may be optionally added by inserting the appropriate common block. Care must be taken when using data from a common block to make sure that it has been computed prior to its attempted use.

Changing a Method Module: Four methods are too complex to be included as a single subroutine. They are the Airfoil Section Module, the Hybrid Theory Module, the Second Order Shock Expansion Module and the Supersonic Wing Potential Flow Module. These techniques are neither short nor easily changed. To replace each module with another technique, the following is recommended.

- Airfoil Section Module - This module starts with subroutine THEORY. To use another set of airfoil section calculations requires the revision of this subroutine.
- Hybrid Theory Module - The second-order potential flow solution of Van Dyke (Hybrid Theory) begins with subroutine HYBRID. Replacement of this method requires changes to subroutine SUPPOT.
- Second-Order Shock Expansion Theory Module - The Second-Order Shock Expansion method is implemented beginning with SOSE. Replacement of this method requires changes to subroutine SUPPOT.
- Supersonic Wing Potential Flow Module - The potential flow method for supersonic wave drag is implemented in subroutine FCAWPF. Replacement of this method is done in FINXCA.

Table 27 Body Alone Aerodynamic Methodology References

Parameter	Subsonic/Transonic ($M < 1.2$)	Supersonic ($M > 1.2$)
Potential Normal Force	Option 1: Nose-cylinder: MBB charts, MBB TN-WE-2-9769 and Boattail: NSWC charts, NSWC-TR-81-156 and Flare: Army charts AMCP 706-280, or Option 2: Slender Body Theory	Option 1 and Option 2: Second Order Shock Expansion, NSWC-TR-81-156, or Van Dyke Hybrid theory, NSWC-TR-81-156, or Modified Newtonian theory, NASA-TND-176
Viscous Normal Force	Jorgensen viscous crossflow, NASA-TR-R-474 and AEDC-TR-75-124	Jorgensen viscous crossflow, NASA-TR-R-474 and AEDC-TR-75-124
Potential Pitching Moment	Option 1: Nose-cylinder: MBB charts, MBB TN-WE-2-9769 and Boattail: NSWC charts, NSWC-TR-81-156 and Flare: Army charts AMCP 706-280, or Option 2: Slender Body Theory	Option 1 and Option 2: Second Order Shock Expansion, NSWC-TR-81-156, or Van Dyke Hybrid theory, NSWC-TR-81-156, or Modified Newtonian theory, NASA-TND-176
Viscous Pitching Moment	Jorgensen viscous crossflow, NASA-TR-R-474 and AEDC-TR-75-124	Jorgensen viscous crossflow, NASA-TR-R-474 and AEDC-TR-75-124
Skin Friction Drag	Turbulent: Van Driest II, MDAC West Handbook Laminar: Blasius, Hoerner Fluid Dynamic Drag Roughness: USAF Datcom section 4.1.5.1	Turbulent: Van Driest II, MDAC West Handbook Laminar: Blasius, Hoerner Fluid Dynamic Drag Roughness: USAF Datcom section 4.1.5.1
Pressure/Wave Drag	$M < M_{crit}$: USAF Datcom section 4.2.3.1 $M > M_{crit}$: Transonic area rule, AIAA-90-0280	Second Order Shock Expansion, NSWC-TR-81-156, or Van Dyke Hybrid theory, NSWC-TR-81-156, or Modified Newtonian theory, NASA-TND-176
Base Drag	Cylinder: NSWC charts, NSWC-TR-92/509 Boattail: NASA method, NASA-TR-R-100 Flare: NSWC charts, NSWC-TR-81-358	Cylinder: NSWC charts, NSWC-TR-92/509 Boattail: NASA method, NASA-TR-R-100 Flare: NSWC charts, NSWC-TR-81-156
Protuberance Drag	$M < 0.6$: Hoerner Fluid Dynamic Drag $M > 0.6$: cubic fairing, AIAA-94-0027	$M < 5.0$: Modified Newtonian theory wit, AIAA-94-0027 $M > 5.0$: Modified Newtonian theory
Axial force at angle of attack	Allen and Perkins Crossflow, NASA TR-1048	Second Order Shock Expansion, NSWC-TR-81-156 Assumed zero for Van Dyke Hybrid and Modified Newtonian theory
Dynamic derivatives	LMSC code, LMSC-D646354 and D646354A Slender Body Theory, AIAA 97-2280	LMSC code, LMSC-D646354 and D646354A Slender Body Theory, AIAA 97-2280
Magnus derivatives	SPIN 73 code, FRL-TR-4588	SPIN 73 code, FRL-TR-4588
Plume effects	not calculated	Chapman Korst model, AIAA 90-0618

Table 28 Body Alone Aerodynamic Methodology Subroutines

Parameter	Subsonic/Transonic (M<1.2)	Supersonic (M>1.2)
Potential Normal Force	Option 1: Nose-cylinder: BDCNAN, BDCNP Boattail: BDCNAB, BDCNP Flare: BDCNAF, BDCNP Option 2: SUBPTS, BDCNP	Option 1 and Option 2: Second Order Shock Expansion: SOSE, BDCNP Van Dyke Hybrid theory: VANDYK, BDCNP Modified Newtonian theory: HYPERS, BDCNP
Viscous Normal Force	CDCS, GETETA, BDCNV	CDCS, GETETA, BDCNV
Potential Pitching Moment	Option 1: Nose-cylinder: BDXCNP, BDCMP Boattail: BDXCNP, BDCMP Flare: BDXCNP, BDCMP Option 2: SUBPTS, BDCMP	Option 1 and Option 2: Second Order Shock Expansion: SOSE, BDCMP Van Dyke Hybrid theory: VANDYK, BDCMP Modified Newtonian theory: HYPERS, BDCMP
Viscous Pitching Moment	CDCS, GETETA, BDCMV	CDCS, GETETA, BDCMV
Skin Friction Drag	SKINF, CAFRIC, BODYCA	SKINF, CAFRIC, SUPBOD
Pressure/Wave Drag	M<Mcrit: BDCAPR, BODYCA M>Mcrit: CDPRES, BODYCA	Second Order Shock Expansion: SOSE, SUPBOD Van Dyke Hybrid theory: VANDYK, SUPBOD Modified Newtonian theory: HYPERS, SUPBOD
Base Drag	BDCAB, BODYCA	BDCAB, SUPBOD
Protuberance Drag	CAPROT, BODYCA	CAPROT, BODYCA
Axial force at angle of attack	BDCALP, BODYCA	SOSE, SUPBOD
Dynamic derivatives	BDAMP, DAMP2	BDAMP, DAMP2
Magnus derivatives	SPIN83, DAMP2	SPIN83, DAMP2
Plume effects		BOTCNM, BOTCA, BASPRS

Table 29 Fin Alone Aerodynamic Methodology References

Parameter	Subsonic ($M < 0.8$)	Transonic ($0.8 < M < 1.4$)	Supersonic ($M > 1.4$)
Airfoil Section Properties	ADDFL-TR-71-87	$M < M_{crit}$: AFFDL-TR-71-87 $M > M_{crit}$: not calculated	not calculated
Potential Normal Force	USAF Datcom section 4.1.3.2	RAS Data Sheets	$\Lambda > 0$: USAF Datcom section 4.1.3.2 $\Lambda < 0$: AFWAL-TR-84-3084 $M > 2.5$ and $\beta AR < 1.35$ and $\Lambda > 0$, AIAA 84-0575
Viscous Normal Force	$\Lambda > 0$: USAF Datcom section 4.1.3.3 $\Lambda < 0$: AFWAL-TR-84-3084	$\Lambda > 0$: USAF Datcom section 4.1.3.3 $\Lambda < 0$: AFWAL-TR-84-3084	$\Lambda > 0$: USAF Datcom section 4.1.3.3 $\Lambda < 0$: AFWAL-TR-84-3084
Chordwise center of pressure (stability)	$\Lambda > 0$: USAF Datcom section 4.1.4.2 $\Lambda < 0$: AFWAL-TR-84-3084	$\Lambda > 0$: USAF Datcom section 4.1.4.2 $\Lambda < 0$: AFWAL-TR-84-3084	$\Lambda > 0$: USAF Datcom section 4.1.4.2 $\Lambda < 0$: AFWAL-TR-84-3084
Chordwise center of Pressure (hinge moment)	$M > 0.4$: Empirical, AIAA-91-0708 $M < 0.4$: $M=0.4$ value used	Empirical (tri-service data base), AIAA-91-0708	Empirical (tri-service data base), AIAA-91-0708
Spanwise center of pressure	$M > 0.4$: Empirical, AIAA-91-0708 $M < 0.4$: $M=0.4$ value used	Empirical (tri-service data base), AIAA-91-0708	Empirical (tri-service data base), AIAA-91-0708
Flap effectiveness (α/δ)	USAF Datcom section 6.1.4.1	cubic fairing	NACA-TR-1041
Skin Friction Drag	MDAC West Handbook Hoerner Fluid Dynamic Drag USAF Datcom section 4.1.5.1	MDAC West Handbook Hoerner Fluid Dynamic Drag USAF Datcom section 4.1.5.1	MDAC West Handbook Hoerner Fluid Dynamic Drag USAF Datcom section 4.1.5.1
Pressure Drag	Hoerner Fluid Dynamic Drag	Hoerner Fluid Dynamic Drag	not applicable
Wave Drag	not applicable	$M < 1.05$: 0 $1.05 < M < 1.4$: Linear fairing	Potential Flow Theory, NWL-TR-3018
Bluntness Drag	USAF Datcom section 4.1.5.1	USAF Datcom section 4.1.5.1	Potential Flow Theory, NWL-TR-3018
Base Drag	Empirical, NWL-TR-2796	Empirical, NWL-TR-2796	Empirical, NWL-TR-2796
Induced Drag	USAF Datcom section 4.1.5.2	USAF Datcom section 4.1.5.2	0

Table 30 Fin Alone Aerodynamic Methodology Subroutines

Parameter	Subsonic (M<0.8)	Transonic (0.8<M<1.4)	Supersonic (M>1.4)
Airfoil Section Properties	THEORY, CLMAX	THEORY, CLMAX	
Potential Normal Force	FCNASB, FCNA	FCNATR, FCNA	FCNASP, FCNA M > 2.5 and $\beta AR < 1.35$ and $\Lambda > 0$, LUCERO, FCNASP, FCNA
Viscous Normal Force	FCNAAS, FCNAA	FCNAAT, FCNAA	FCNAAH, FCNAA
Chordwise center of pressure (stability)	$\Lambda > 0$: FALCP, FINCM $\Lambda < 0$: FWDXAC, FINCM	$\Lambda > 0$: FALCP, FINCM $\Lambda < 0$: FWDXAC, FINCM	$\Lambda > 0$: FALCP, FINCM $\Lambda < 0$: FWDXAC, FINCM
Chordwise center of Pressure (hinge moment)	HMCP	HMCP	HMCP
Spanwise center of pressure	YCP	YCP	YCP
Flap effectiveness (α/δ)	FLAPS	FLAPS	FLAPS
Skin Friction Drag	SKINF, CAFRIC, FINXCA	SKINF, CAFRIC, FINXCA	SKINF, CAFRIC, FINXCA
Pressure Drag	FINCAP, FINXCA	FCAWT, FINXCA	
Wave Drag		FINXCA	FCAWPF, FINXCA
Bluntness Drag	FCALE, FINXCA	FCALE, FINXCA	FCAWPF, FINXCA
Base Drag	FINCAB, FINXCA	FINCAB, FINXCA	FINCAB, FINXCA
Induced Drag	FCALP, FINXCA	FCALP, FINXCA	

Table 31 Inlet Aerodynamic Methodology References

Parameter	Subsonic ($M < 1.0$)	Supersonic ($M > 1.0$)
Potential Normal Force	Engineering method, AIAA 90-3091	Engineering method, AIAA 90-3091
Viscous Normal Force	Jorgensen viscous crossflow, NASA-TR-R-474 and AEDC-TR-75-124	Jorgensen viscous crossflow, NASA-TR-R-474 and AEDC-TR-75-124
Potential Pitching Moment	Engineering method, AIAA 90-3091	Engineering method, AIAA 90-3091
Viscous Pitching Moment	Jorgensen viscous crossflow, NASA-TR-R-474 and AEDC-TR-75-124	Jorgensen viscous crossflow, NASA-TR-R-474 and AEDC-TR-75-124
Spanwise center of pressure		
Skin Friction Drag	Turbulent: Van Driest II, MDAC West Handbook Laminar: Blasius, Hoerner Fluid Dynamic Drag Roughness: USAF Datcom section 4.1.5.1	Turbulent: Van Driest II, MDAC West Handbook Laminar: Blasius, Hoerner Fluid Dynamic Drag Roughness: USAF Datcom section 4.1.5.1
Pressure/Wave Drag	$M < M_{crit}$: USAF Datcom section 4.2.3.1 $M > M_{crit}$: Transonic area rule, AIAA-90-0280	Supersonic Area rule, AIAA-90-0280
Additive Drag	not applicable	Engineering method, AIAA 91-0712
Axial force at angle of attack	0	0

Table 32 Inlet Aerodynamic Methodology Subroutines

Parameter	Subsonic ($M < 1.0$)	Supersonic ($M > 1.0$)
Potential Normal Force	CNPTWO, POTAR1, ILTARO or CNPTWO, POTAR2, ILTARO or CNPAXI, POTAR3, ILTARO	CNPTWO, POTAR1, ILTARO or CNPTWO, POTAR2, ILTARO or CNPAXI, POTAR3, ILTARO
Viscous Normal Force	ILTCDC, ILTCFD, ILTVIS, ILTARO	ILTCDC, ILTCFD, ILTVIS, ILTARO
Potential Pitching Moment	CNPTWO, POTAR1, ILTARO or CNPTWO, POTAR2, ILTARO or CNPAXI, POTAR3, ILTARO	CNPTWO, POTAR1, ILTARO or CNPTWO, POTAR2, ILTARO or CNPAXI, POTAR3, ILTARO
Viscous Pitching Moment	ILTCDC, ILTCFD, ILTVIS, ILTARO	ILTCDC, ILTCFD, ILTVIS, ILTARO
Spanwise center of pressure	ILTARO	ILTARO
Skin Friction Drag	SKINF, CAFRIC, ILTARO	SKINF, CAFRIC, ILTARO
Pressure/Wave Drag	$M < M_{crit}$: BDCAPR, ILTARO $M > M_{crit}$: CDPRES, ILTARO	CDPRES, ILTARO
Additive Drag	not applicable	IAD2D, ILTARO or IADAXI, ILTARO
Axial force at angle of attack		

Table 33 Fin-Body Synthesis Aerodynamic Methodology References

Parameter	Subsonic (M<1.0)	Supersonic (M>1.0)
Body-Fin Upwash, K_w	Empirical correlation, AIAA 96-3395 Folding fin: AIAA 94-0027	Empirical correlation, AIAA 96-3395 Folding fin: AIAA 94-0027
Fin-Body Carryover, K_B	Slender body theory, NACA-TR-1307	Slender body theory, NACA-TR-1307 and AIAA Journal, May 1981
Body-Fin Upwash Center of Pressure, $x_{cp_{WB}}$	$\Lambda > 0$: USAF Datcom section 4.1.4.2 $\Lambda < 0$: AFWAL-TR-84-3084	$\Lambda > 0$: USAF Datcom section 4.1.4.2 $\Lambda < 0$: AFWAL-TR-84-3084
Body-Fin-Body Carryover Center of Pressure, $x_{cp_{BW}}$	Lifting line theory, NACA-TR-1307 and AIAA 94-0027	Slender body theory, NACA-TR-1307 and AIAA Journal, August 1982
Fin Deflection, Λ_{II}	Slender body theory, AGARD-R-711	Slender body theory, AGARD-R-711
Equivalent angle of attack	AIAA J. Spacecraft&Rockets, July-Aug 1983	AIAA J. Spacecraft&Rockets, July-Aug 1983
Body Vortex Strength	Empirical, NWC-TP-5761	Empirical, NWC-TP-5761
Body Vortex Track	Empirical, NWC-TP-5761	Empirical, NWC-TP-5761
Fin Vortex Strength	Line vortex theory, NACA-TR-1307	Line vortex theory, NACA-TR-1307
Fin Vortex Track	along velocity vector	along velocity vector
Dynamic Derivatives	Equivalent angle of attack, AIAA 97-2280	ALPEQ2, FDAMP, DAMP2

Table 34 Fin-Body Synthesis Aerodynamic Methodology Subroutines

Parameter	Subsonic (M<1.0)	Supersonic (M>1.0)
Body-Fin Upwash, K_w	KWBNEW, SYNTHS Folding fin: PANLCN	KWBNEW, SYNTHS Folding fin: PANLCN
Fin-Body Carryover, K_B	CARRYO, SYNTHS	CARRYO, SYNTHS
Body-Fin Upwash Center of Pressure, $x_{cp_{WB}}$	$\Lambda > 0$: FALCP, CARRYO, SYNTHS $\Lambda < 0$: FWDXAC, CARRYO, SYNTHS	$\Lambda > 0$: FALCP, CARRYO, SYNTHS $\Lambda < 0$: FWDXAC, CARRYO, SYNTHS
Body-Fin-Body Carryover Center of Pressure, $x_{cp_{BW}}$	CARRYO, SYNTHS	CARRYO, SYNTHS
Fin Deflection, Λ_{II}	FINFIN, PANLCN	FINFIN, PANLCN
Equivalent angle of attack	ALPEQ, PANLCN	ALPEQ, PANLCN
Body Vortex Strength	CLVR, ALPEQ, PANLCN	CLVR, ALPEQ, PANLCN
Body Vortex Track	CLVR, ALPEQ, PANLCN	CLVR, ALPEQ, PANLCN
Fin Vortex Strength	VRINTS, SYNTHS	VRINTS, SYNTHS
Fin Vortex Track	SFWRW, SVTRAK, SYNTHS	SFWRW, SVTRAK, SYNTHS
Dynamic Derivatives	ALPEQ2, FDAMP, DAMP2	ALPEQ2, FDAMP, DAMP2

